



Whirl Away Surface Prep Tools

Surface Prep Tools

4 IN WHIRL AWAY TOOL

- Attaches to most sanders, grinders, drills, polishers, (electric, pneumatic, hydraulic)
- Built in safety guard
- Balanced design for easy operation
- Operates under water with pneumatic tool
- Environmentally safe
- Fits 5/8" - 11 shaft (metric available)
- No lubrication required
- Drive adaptor for 3/8" ro 1/2" drill chuck available

Replacement parts and teeth available.

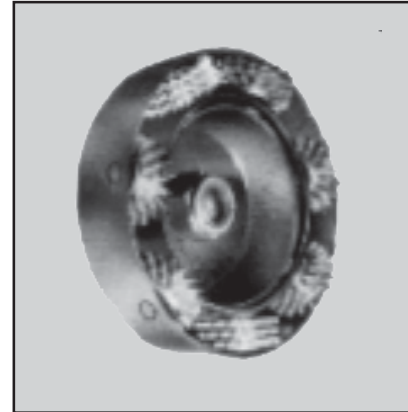

6 IN WHIRL AWAY TOOL

- Attaches to most sanders, grinders, drills, polishers, (electric, pneumatic, hydraulic)
- Built in safety guard
- Balanced design for easy operation
- Operates under water with pneumatic tool
- Environmentally safe
- Fits 5/8" - 11 shaft (metric available)
- No lubrication required
- Drive adaptor for 3/8" ro 1/2" drill chuck available

Replacement parts and teeth available.

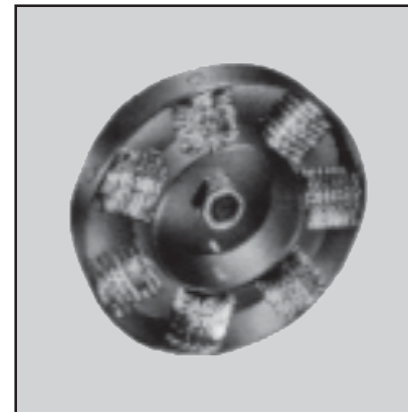



1074 Kenran Industrial Dr.
St. Louis, MO 63137
Phone: 1-800-381-9968

HUMCO MISCELLANEOUS

Aurand Electric and Pneumatic Tools



MODEL K7-1 115v
K7-2 230v

Cleaning area: 5" wide,
1/4 HP AC or DC universal
motor. Weight: 9 lbs.
Additional cutter bundles
#674: (set of 2)



MODEL M5-1 115v
M5-2 230v

Cleaning area: 8" wide,
1/2 HP AC or DC universal
motor. Weight: 23 lbs.
Additional cutter bundles
#90M: (set of 2)



MODEL K7-1E 115v
K7-2E 230v

Cleaning area: 8" wide,
1/4 HP AC or DC universal
motor. Weight: 11 lbs.
Additional cutter bundles
#674-E: (set of 4)



MODEL M5-1E 115v
M5-2E 230v

Cleaning area: 12" wide,
2 1/2 HP AC or DC universal
motor. Weight: 28 lbs.
Additional cutter bundles
#90ME: (set of 4)

MODEL	CLEANING AREA	POWER SUPPLY	HORSE-POWER	MODEL
K7-1	5" WIDE	115 V	1/4	9 LBS.
K7-2		230 V		
KP-5		AIR	3/4	3/4 LBS.
K7-1E	8" WIDE	115 V	1/4	11 LBS.
K7-2E		230 V		
KP5E		AIR	3/4	9 LBS.
M5-1	8" WIDE	115 V	1/2	21 LBS.
M5-2		230 V		
MP6		AIR	2 1/2	16 LBS.
M5-1E	12"	115 V	2 1/2	28 LBS.
M5-2E		230 V		
MP6E		AIR		24 LBS.
W1G	4 3/4"	GASOLINE	5	90 LBS.
W1E	WIDE	115/230V	2	97 LBS.



Electric Tools

Electric tools are available in 115 and 230 volt models. 15 feet of three conductor cable is included.

Pneumatic Tools

Pneumatic tools feature rotary type air motors, free from toggles, pistons, or reciprocating parts to eliminate vibration. Tools operate on 42 CFM, 70-100 PSI.

Tools available with collector



MODEL KP5

Cleaning area: 5" wide,
3/4 HP motor. Weight: 6 lbs.
Additional cutter bundles
#674, (set of 2)



MODEL MP6

Cleaning area: 8" wide,
2 1/2 HP motor. Weight: 16 lbs.
Additional cutter bundles
#90M: (set of 2)



MODEL KP5E

Cleaning area: 8" wide,
3/4 HP motor. Weight: 7.5 lbs.
Additional cutter bundles
#674E, (set of 4)



MODEL MP6E

Cleaning area: 12" wide,
2 1/2 HP motor. 48-inch
detachable handle allows
stand-up use on large, flat
areas. Weight: 22 lbs.
Additional cutter bundles
#90ME: (set of 4)



1074 Kenran Industrial Dr.
St. Louis, MO 63137
Phone: 1-800-381-9968

HUMCO MISCELLANEOUS

Aurand Tools and Accessories



Surface Prep



Deck Scaling



Coating Paint Removal

Where can you get
SO MUCH from such
a small investment?

ALL AURAND TOOLS FEATURE:

ADJUSTABLE DEPTH SHOE that the operator sets to limit the impact of the cutters. This not only protects the surface being cleaned but also insures uniform cleaning action and prevents excessive wear on the cutters.

CAST ALUMINUM HOUSINGS that offer the user a tough, durable tool that is still lightweight and easy to handle.

BEST POSSIBLE GEAR DESIGN with a hardened and ground worm driving a bronze worm wheel for maximum life and effectiveness.

SEPARATE handle, safety guard, cutter bundles, motor housing, and front head assembly to make repair or replacement easier and less expensive.

Accessories Cutter Bundles



Aurand "M" Series tools can be fitted with a wire brushes for light scale and clean up applications.

Important Facts

Aurand's mission is to provide the most reliable tools of the finest quality for surface preparation and rust removal. We strive to have absolute customer satisfaction.

With our long-lasting user replaceable cutter bundles you can use our tools as a concrete grinder, scarifier, paint chipper and deck scaler while producing the highest output of your maintenance crews.

Wire Brushes





1074 Kenran Industrial Dr.
St. Louis, MO 63137
Phone: 1-800-381-9968

HUMCO MISCELLANEOUS

Chipping Hammers

W-Style Chipping Hammer

When conventional tapered style retainer chippers fail prematurely, the acme thread style chipping hammers are put into service. The heavy-duty retainer mechanism has two sets of steel sleeves and a rubber bumper to disperse and absorb the blows of the chisel. W-style chippers use oval or round collar chisels. **See page 1004 for additional accessories. Please specify hex or round shank.**



MP-W2R
Chipping Hammer (sold with retainer)

Chipping Hammer Retainer & Parts

Retainer HHW1-300	Lower Washer HHW1-213	O-Ring R000A2-103	Retainer Spring 24SR-207	Upper Washer H3R-31	Rubber Bumper H3R-203

Chipping Hammers

Model No.	Blows Per Minute	Stroke	Bore	Rec'd Hose Size	Length	Weight	Air Inlet	Avg. Air Consumption
MP-W1H	2500	1"	1-1/8"	1/2"	15-7/8"	14.75 lbs.	3/8"	28 cfm
MP-W1R	2500	1"	1-1/8"	1/2"	15-7/8"	14.75 lbs.	3/8"	28 cfm
MP-W2H	2300	2"	1-1/8"	1/2"	16-3/8"	15.50 lbs.	3/8"	28 cfm
MP-W2R	2300	2"	1-1/8"	1/2"	16-3/8"	15.50 lbs.	3/8"	28 cfm
MP-W3H	1725	3"	1-1/8"	1/2"	18-1/4"	16.60 lbs.	3/8"	29 cfm
MP-W3R	1725	3"	1-1/8"	1/2"	18-1/4"	16.60 lbs.	3/8"	29 cfm
MP-W4H	1480	4"	1-1/8"	1/2"	19-1/4"	17.50 lbs.	3/8"	29 cfm
MP-W4R	1480	4"	1-1/8"	1/2"	19-1/4"	17.50 lbs.	3/8"	29 cfm

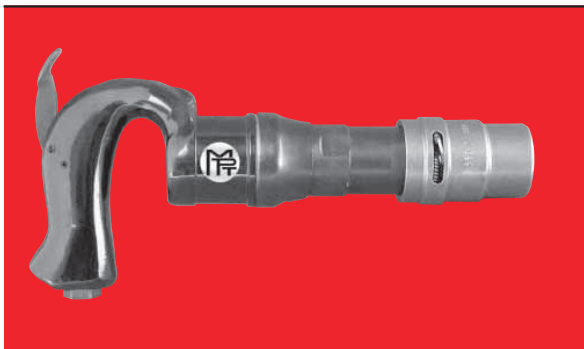

Michigan Pneumatic Model MP-K2L-H - Hex
Model MP-K2L-R - Round

Chipping Hammer

Smallest line of chippers featuring standard .580 hex or .680 round shank bushing. **Parts interchangeable with Ingersoll-Rand K2L models. Please specify hex or round shank.**

Blows Per Minute	3600	Length	12"
Stroke	1-3/4"	Weight	8 lbs.
Bore	7/8"	Air Inlet Thread	1/4"

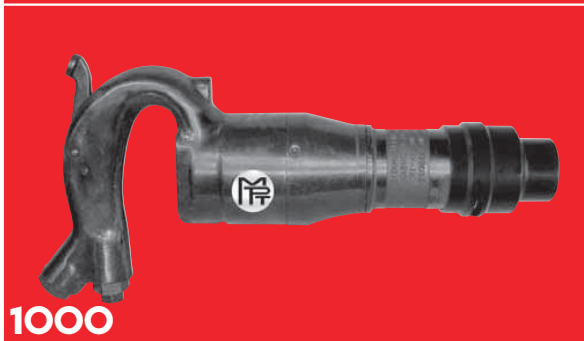

Michigan Pneumatic Model MP-MA1H - Hex
Model MP-MA1R - Round

Chipping Hammer

You cannot afford to do overhead concrete repair work or chipping without one. Lightweight chipper for heavy-duty jobs. **Parts interchangeable with MasterPower or Black & Decker models. Please specify hex or round shank.**

Blows Per Minute	2800	Length	11-7/8"
Stroke	1"	Weight	12.5 lbs.
Bore	1-1/8"	Air Inlet Thread	3/8"



1074 Kenran Industrial Dr.
St. Louis, MO 63137
Phone: 1-800-381-9968

HUMCO MISCELLANEOUS

Scaling/Needle Hammers



Michigan Pneumatic

Scaling/Needle Hammers

Popular scaler for its short length and light weight. Very powerful for its size. Ideal for use as a chisel gun for cutting metal, or a needle gun for cleaning contoured surfaces. Removes rust or paint and de-slugs metal surfaces. Lever throttle offers easy, accurate control of chiseling action. Used for scaling in assembly shops, steel mills and foundries. Can also be used to remove caulking.
2527NS-ASM Needle Attachment

Takes style 100 - 1/2" quarter octagon chisel.

Model	Bore	Stroke	BPM	Length	Weight	Air Inlet	CFM
MP-25	1"	7/8"	4000	8-3/8"	3.75 lbs.	1/4"	4
MP-25NS	1"	7/8"	4000	16-3/8"	5.75 lbs.	1/4"	4

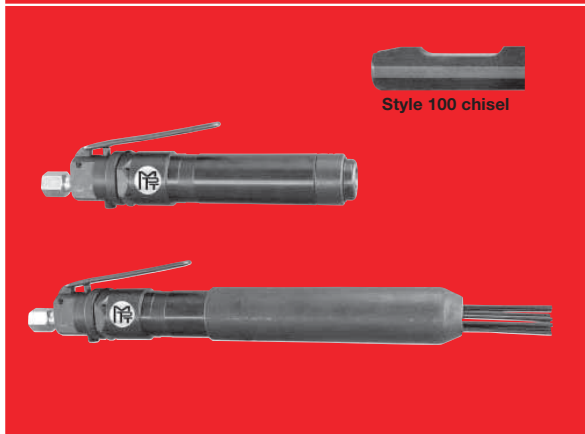

Michigan Pneumatic

Scaling/Needle Hammers

Ideal for removing weld splatter, rust, scale and debris from hard to reach surfaces. Useful in oilfields, fabrication shops, petro-chemical plants and foundries. **Gooseneck handle and push throttle hammers also available. Parts are interchangeable with Ingersoll-Rand Model 182.**
1393 Needle Attachment

Takes style 100 - 1/2" quarter octagon chisel.

Model	Bore	Stroke	BPM	Length	Weight	Air Inlet	CFM
MP-182L	15/16"	1-1/16"	4000	9"	4.00 lbs.	1/4"	13
MP-182LNS	15/16"	1-1/16"	4000	15"	5.75 lbs.	1/4"	13

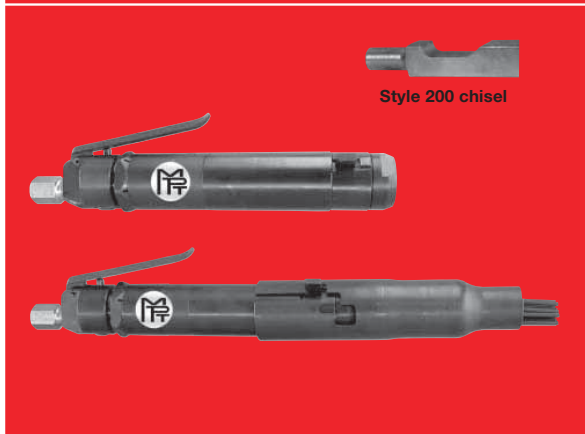

Michigan Pneumatic

Scaling/Needle Hammers

Excellent for removing weld splatter, rust, paint and other debris from many different and unusual surfaces and in hard-to-reach places. Ideal for construction sites, fabrication shops, refineries and foundries. **Gooseneck handle and push throttle hammers also available. Parts interchangeable with Cleco Model B1 scaler.**
1392 Needle Attachment

Takes style 200 - 1/2" square chisel.

Model	Bore	Stroke	BPM	Length	Weight	Air Inlet	CFM
MP-1BL	1"	1-1/8"	4600	10"	4.625 lbs.	1/4"	12
MP-1BLNS	1"	1-1/8"	4600	17"	6.200 lbs.	1/4"	12

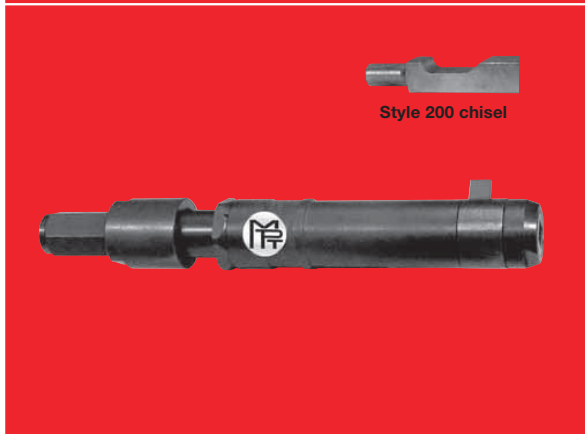

Michigan Pneumatic Model MP-CK1SR

Coke Oven Scaler - Push Throttle

Designed to be attached to long air pipes to remove debris from oven bricks used in the steel industry. Features a simple push throttle.

Takes style 200 - 1/2" square chisel.

Bore	1"	Length	12-1/2"
Stroke	1-1/8"	Weight	4.5 lbs.
Blows Per Minute	4600	Air Inlet Thread	1/2"
Rec'd Hose Size	1/4"	Avg. Air Consumption:	6 cfm



1074 Kenran Industrial Dr.
St. Louis, MO 63137
Phone: 1-800-381-9968

HUMCO MISCELLANEOUS

Scaling Hammers

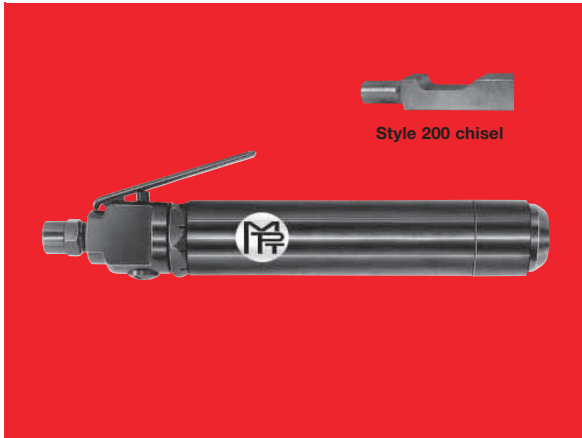

Michigan Pneumatic Model MP-L-1SR

Scaling Hammer - Lever Throttle

New, improved design features smooth action throttling characteristics. Easy to handle, powerful tool widely used as a general purpose hammer for chipping stone, metal, concrete, brick and for carving wood. Chisels are held firmly in place and cannot rotate. Chisels are easily changed with a quick release lever. **Parts interchangeable with Cleco B1A scaler. Model MP-L-1SR-1392 needle scaler available.**

1392 Needle Attachment

Takes style 200 - 1/2" square chisel.

Bore	1"	Length	10-1/4"
Stroke	1-1/8"	Weight	3.625 lbs.
Blows Per Minute	4600	Air Inlet Thread	1/4"
Rec'd Hose Size	1/4"	Avg. Air Consumption:	6 cfm

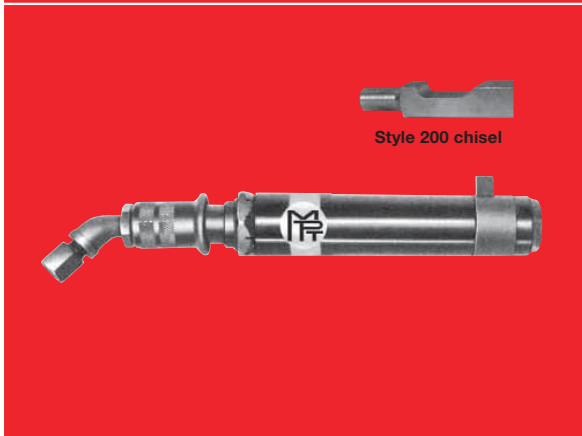

Michigan Pneumatic Model MP-P-1SR

Scaling Hammer - Push Throttle

Popular scaling hammer for its high speed action, short length and light weight. Widely used for light chipping, caulking and scaling in steel mills, foundries and assembly shops. Ideal for close quarter work. **Parts interchangeable with Cleco B1A scaler. Model MP-P-1SR-1392 needle scaler available.**

1392 Needle Attachment

Takes style 200 - 1/2" square chisel.

Bore	1"	Length	12"
Stroke	1-1/8"	Weight	3.75 lbs.
Blows Per Minute	4600	Air Inlet Thread	1/4"
Rec'd Hose Size	1/4"	Avg. Air Consumption:	6 cfm



Michigan Pneumatic Model MP-G-1SR

Scaling Hammer - Gooseneck Throttle

Designed for long-term scaling jobs, featuring a strategically positioned, ergonomic handle for comfortable operation. The handle allows the operator's wrist to function in natural position, reducing fatigue. **Parts interchangeable with Cleco B1-A-BV. Model MP-G-1SR-1392 needle scaler available.**

1392 Needle Attachment

Takes style 200 - 1/2" square chisel.

Bore	1"	Length	11-1/2"
Stroke	1-1/8"	Weight	3.75 lbs.
Blows Per Minute	4600	Air Inlet Thread	1/4"
Rec'd Hose Size	1/4"	Avg. Air Consumption:	6 cfm



Michigan Pneumatic Model MP-PG-1SR

Scaling Hammer - Offset Grip Throttle

A built-in power regulator allows the operator to adjust the hitting power to prevent damage to softer castings and surfaces. Cleans rust, scale, paint and other coatings from nearly any surface. **Parts interchangeable with Cleco B1-A-BV. Model MP-PG-1SR-1392 needle scaler available.**

1392 Needle Attachment

Takes style 200 - 1/2" square chisel.

Bore	1"	Length	10-3/4"
Stroke	1-1/8"	Weight	5 lbs.
Blows Per Minute	4600	Air Inlet Thread	1/4"
Rec'd Hose Size	1/4"	Avg. Air Consumption:	6 cfm



1074 Kenran Industrial Dr.
St. Louis, MO 63137
Phone: 1-800-381-9968

Scaling Hammers

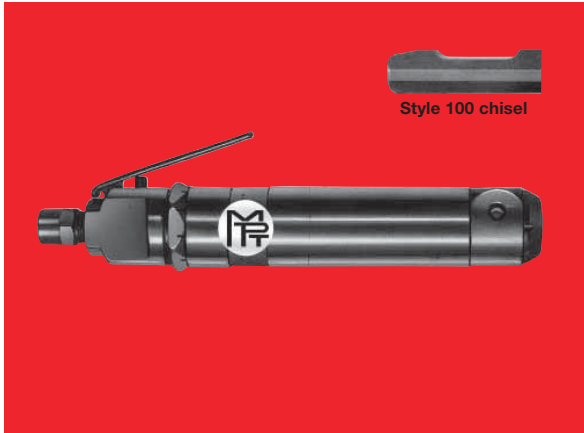

Michigan Pneumatic Model MP-L-455C Scaling Hammer - Lever Throttle

Controlled by a lever type throttle. Squeeze lever for hammer action. Very powerful for its capacity. Good for removing flux and spatter after welding. Equipped with a ball type retainer. **Parts interchangeable with Cleco BR scaler. Model MP-L-455C-1394 needle scaler available.**
1394 Needle Attachment

Takes style 100 - 1/2" quarter octagon chisel.

Bore	1"	Length	10-3/8"
Stroke	1-1/8"	Weight	4 lbs.
Blows Per Minute	4200	Air Inlet Thread	1/4"
Rec'd Hose Size	1/4"	Avg. Air Consumption:	6 cfm

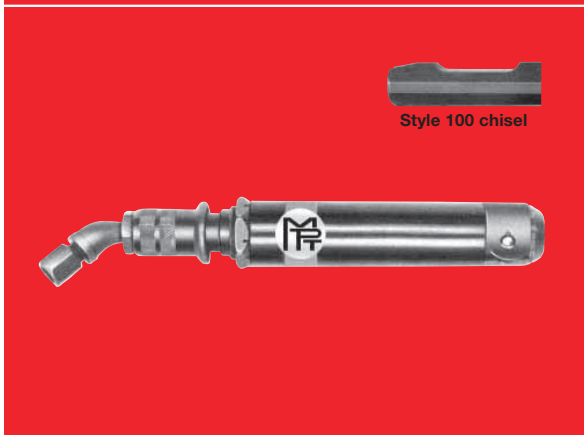

Michigan Pneumatic Model MP-P-455C Scaling Hammer - Push Throttle

Controlled by a push type throttle. Push the throttle for hammer action. Widely used for scaling and chipping in shipyards and machine shops. Also used for light scale removal on airplanes and for ironing sheet metal. **Parts interchangeable with Cleco BR scaler. Model MP-P-455C-1394 needle scaler available.**
1394 Needle Attachment

Takes style 100 - 1/2" quarter octagon chisel.

Bore	1"	Length	12-1/8"
Stroke	1-1/8"	Weight	4 lbs.
Blows Per Minute	4200	Air Inlet Thread	1/4"
Rec'd Hose Size	1/4"	Avg. Air Consumption:	6 cfm



Michigan Pneumatic Model MP-G-455C Scaling Hammer - Gooseneck Throttle

Features power for the heaviest scaling jobs and an ergonomic handle to reduce operator fatigue and increase production. Outstanding for scaling castings and removing paint or rust. **Model MP-G-455C-1394 needle scaler available.**
1394 Needle Attachment

Takes style 100 - 1/2" quarter octagon chisel.

Bore	1"	Length	12-7/8"
Stroke	1-1/8"	Weight	3.875 lbs.
Blows Per Minute	4200	Air Inlet Thread	1/4"
Rec'd Hose Size	1/4"	Avg. Air Consumption:	6 cfm



Michigan Pneumatic Model MP-PG-455C Scaling Hammer - Offset Grip Throttle

Features an offset handle for operator comfort and single finger operation. Ideal for scaling rust removal, peening and tank cleaning. **Model MP-PG-455C-1394 needle scaler available.**
1394 Needle Attachment

Takes style 100 - 1/2" quarter octagon chisel.

Bore	1"	Length	10"
Stroke	1-1/8"	Weight	5.5 lbs.
Blows Per Minute	4600	Air Inlet Thread	1/4"
Rec'd Hose Size	1/4"	Avg. Air Consumption:	6 cfm



1074 Kenran Industrial Dr.
St. Louis, MO 63137
Phone: 1-800-381-9968

HUMCO MISCELLANEOUS

Hammers and Scalers Accessories

Style 100

1/2" Quarter Octagon Stock



Designed for: Michigan Pneumatic Models MP-L-455C & MP-P-455C, Chicago Pneumatic, Thor, Ingersoll-Rand (172 & 182), Rockwell, ARO and Sioux scalers.

Style 200

1/2" Square Stock



Designed for: Michigan Pneumatic Models MP-L-1SR & MP-P-1SR, Chicago Pneumatic (9356), Ingersoll-Rand (183), Cleco, ARO and Rotor scalers.

Style 300

1/2" Quarter Octagon Stock



Designed for: Master Power and Black & Decker scalers.

	Blade Style	Length	Width of Cut	Style 100	Style 200	Style 300
Blank Chisel		7"	-	395	391	385
		12"		395-12	391-12	385-12
		18"		395-18	391-18	385-18
Narrow Flat Chisel		7"	3/4"	396	392	386
		12"		396-12	392-12	386-12
		18"		396-18	392-18	386-18
Wide Scaling Chisel		7"	1-3/8"	397	393	387
		12"		397-12	393-12	387-12
		18"		397-18	393-18	387-18
Angle Scaling Chisel		7"	1-3/8"	398	394	388
		12"		398-12	394-12	388-12
		18"		398-18	394-18	388-18
2" Scraper & 3" Scraper		7"	2"	399	390	389
		7"	3"	399-3	390-3	-
Cape Chisel		7"	1/4"	3226	3232	-
Diamond Point Chisel		7"	1/4"	3224	3230	-
Round Nose Chisel		7"	1/4"	3225	3231	-
Non-Sparking Chisel		8"	2"	380-BC	-	-

Please specify part number when ordering. Longer lengths and other blade styles also available.

Complete Needle Scaler Attachment and Replacement Parts



Needle



Needle Tube



Spring Seat
(1393 & IR style only)



Spring



Needle Holder



Driver

Model 1392 Needle Attachment
Fits MP-1SR Series & Cleco

Model 1393 Needle Attachment
Fits MP-182 Series & Ingersoll-Rand

Model 1394 Needle Attachment
Fits MP-455C Series & CP-455

Replacement Parts for Model 1392

MPT Part No.	Cleco Part No.	Description
1370	834779	Needle Tube
1371	834044	Spring
3mm19	834024	Needle Set
375	834046	Needle Holder
373	834045	Driver

Replacement Parts for Model 1393

MPT Part No.	IR Part No.	Description
1380	NS11-A24	Needle Tube
NS11-A25	NS11-A25	Spring Seat
1381	NS11-27	Spring
3mm19	NS11-122	Needle Set
NS11-21	NS11-21	Needle Holder
371	NS11-20	Driver

Replacement Parts for Model 1394

MPT Part No.	CP Part No.	Description
1350	P100151	Needle Tube
1371	P100150	Spring
3mm19	P10046	Needle Set
375	P100145	Needle Holder
374	P100144	Driver



1074 Kenran Industrial Dr.
St. Louis, MO 63137
Phone: 1-800-381-9968

HUMCO MISCELLANEOUS

Needle Scalers



MP-96310 Weldflux Scaler



Style 100 chisel



MP-96311 Needle Scaler



MP-96313 Needle Scaler

Michigan Pneumatic

Weldflux/Needle Scalers

Features include: Sturdy, lightweight design, easy to handle, high power to weight ratio, unique front exhaust system, plated piston for long tool life. **Uses Rockwell scaler parts. Please specify model.**

Replacement Needles

3mm19 3mm Needle Set (19 pc.)

Takes style 100 - 1/2" quarter octagon chisel.

Model	Bore	Stroke	BPM	Length	Weight	Air Inlet	CFM
MP-96310	1"	1-3/16"	1850	10"	4.375 lbs.	1/4"	12
MP-96311	1"	1-3/16"	1850	11-1/4"	4.375 lbs.	1/4"	12
MP-96313	1"	1-3/16"	1850	19-1/4"	6.5 lbs.	1/4"	12

Nitto Kohki Model JC-20

Needle Scaler

Ideal for cleaning castings, removing welding slag, barnacles, and any type of residue. Tool includes one set of 2mm and one set of 3mm flat needles with needle supporters for each size.

Replacement Parts

00A342-29 2mm Needle Set (29 pc.) **00A338** 2mm Supporter
00A341-12 3mm Needle Set (12 pc.) **00A337** 3mm Supporter
00A332 Piston **00A336** Anvil

Piston Diameter	19/32"	Length	13-1/2"
Stroke	1.1"	Weight	5.3 lbs.
Blows Per Minute	4000	Air Inlet Thread	3/8"
Rec'd Hose Size	3/8"	Avg. Air Consumption:	7 cfm



Nitto Kohki Model JT-20

Ergonomic Needle Scaler

This lightweight, ergonomic needle scaler is used for de-slagging welds, cleaning brick, stonework, boats and many other surfaces. Ideal for heavy paint removal. The needles conform to any surface contour.

Replacement Parts

00A342-29 2mm Needle Set (29 pc.) **00A338** 2mm Supporter
00A341-12 3mm Needle Set (12 pc.) **00A337** 3mm Supporter
00A332 Piston **00A336** Anvil

Bore	25/32"	Length	13-37/64"
Stroke	21/32"	Weight	5.3 lbs.
Blows Per Minute	4000	Air Inlet Thread	3/8"
Rec'd Hose Size	3/8"	Avg. Air Consumption:	7.8 cfm



Nitto Kohki Model JEX-20

Needle Scaler

This ergonomic needle scaler is used for cleaning brick and stonework, de-slagging welds, cleaning boat hulls and many other surfaces. Ideal for heavy paint removal.

Replacement Parts

00A342-29 2mm Needle Set (29 pc.) **00A338** 2mm Supporter
00A341-12 3mm Needle Set (12 pc.) **00A337** 3mm Supporter
00A332 Piston **00A336** Anvil

Bore	51/64"	Length	13-11/16"
Stroke	1.1"	Weight	6.1 lbs.
Blows Per Minute	4000	Air Inlet Thread	3/8"
Rec'd Hose Size	3/8"	Avg. Air Consumption:	7.8 cfm





1074 Kenran Industrial Dr.
St. Louis, MO 63137
Phone: 1-800-381-9968

Nitto Kohki Needle Scalers



Nitto Kohki Model JC-16 Needle Scaler

Used for removing rust, cleaning metals, peening welded joints and cleaning hardened concrete from construction equipment. Tool includes two sets of 2mm flat needles.

Replacement Parts

00A291-29	2mm Needle Set (29 pc.)	00A290	2mm Supporter
00A288	Piston	00A289	Anvil

Piston Diameter	5/8"	Length	11"
Stroke	0.86"	Weight	3.1 lbs.
Blows Per Minute	4000	Air Inlet Thread	3/8"
Rec'd Hose Size	3/8"	Avg. Air Consumption:	3.5 cfm

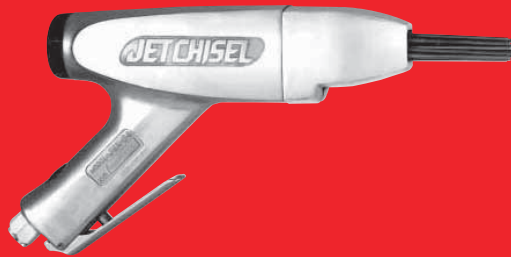

Nitto Kohki Model JEX-24 Needle Scaler

Versatile design for working in any confined space. Ideal for de-slagging, removing rust, paint or scale from irregular or curved surfaces. Tool includes one set of 3mm flat needles.

Replacement Parts

00A342-53	2mm Needle Set (53 pc.)	02A244	2mm Supporter
00A341-23	3mm Needle Set (23 pc.)	02A245	3mm Supporter
02A242	Piston	02A243	Anvil

Piston Diameter	15/16"	Length	13-3/4"
Stroke	1.1"	Weight	6 lbs.
Blows Per Minute	4000	Air Inlet Thread	3/8"
Rec'd Hose Size	3/8"	Avg. Air Consumption:	7.8 cfm



Nitto Kohki Model JEX-28 Needle Scaler

Cleans and descales jobs quickly. Gets deep into corners, uneven surfaces and curves. Tool includes 2 sets of 3mm flat needles and 2 sets of 4mm point needles with needle supporters for each size.

Replacement Parts

00A342-66	2mm Needle Set (66 pc.)	01A499	2mm Supporter
00A341-28	3mm Needle Set (28 pc.)	01A461	3mm Supporter
00A402-14	4mm Needle Set (14 pc.)	01A462	4mm Supporter
00A395	Piston	00A399	Anvil

Piston Diameter	1-3/32"	Length	14-3/4"
Stroke	1.18"	Weight	7.7 lbs.
Blows Per Minute	4500	Air Inlet Thread	3/8"
Rec'd Hose Size	3/8"	Avg. Air Consumption:	8.8 cfm



Nitto Kohki Model EJC-32A Electric Needle Scaler

Applications include removing weld splatters and surface processing on concrete and rocks. Also excellent for descaling paint or rust, removing sand from casted parts, and removing barnacles from ocean vessels. Features a slim barrel design, double insulated, and a free subhandle that positions to best fit the working situation. **Also available in 220 volt AC, Model EJC-32A-220.**

Replacement Parts

00A342-32	2mm Needle Set (32 pc.)	TP16475	2mm Supporter
00A341-15	3mm Needle Set (15 pc.)	TP16301	3mm Supporter
TP16339	Piston	TP16302	Anvil

Power Supply	AC 115V 60Hz	Current	2.8A
Power Consumption	300W	Length	20-1/2"
Stroke Speed	3000/min.	Weight	9.9 lbs.