



1074 Kenran Industrial Dr.  
St. Louis, MO 63137  
Phone: 1-800-381-9968

# HUMCO RIGGING/RATCHETS

## Wire Rope Cutters



Model 1  
3/4" capacity



Model 1A  
1 1/16" capacity



Model 2  
1 1/2" capacity

The original portable tools invented in 1928 by Morse-Starrett to cut wire rope. Actuated by striking with a hammer, they are easy to operate and will give a superior performance without jamming. They are precision-engineered to deliver a cut without affecting the original roundness of the wire rope. The blades and dies are made of the finest tool steel available, heat-treated, and ground to close tolerances.

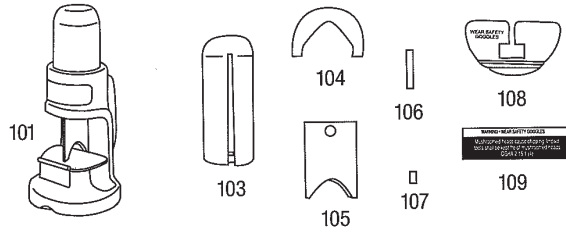

Model 1 (light duty):

Part no.	Description	Packed Weight
101	Cutter complete	8 lbs.
102	Casting base	4 lbs.
103	Plunger	3 lbs.
104	Die (set)	4 oz.
105	Blade (with pin)	2 oz.

Part no.	Description	Packed Weight
106	Blade pin only	1 oz.
107	Plunger guide pin	1 oz.
108	Guard	1 oz.
109	Warning decals	

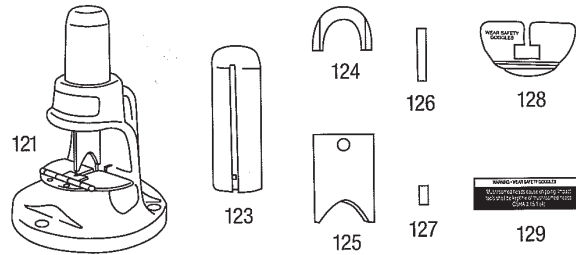

Model 1A (heavy duty):

Part no.	Description	Packed Weight
121	Cutter complete	17 lbs.
122	Casting base	12 lbs.
123	Plunger	4 lbs.
124	Die (set)	7 oz.
125	Blade (with pin)	2 oz.

Part no.	Description	Packed Weight
126	Blade pin only	1 oz.
127	Plunger guide pin	1 oz.
128	Guard	2 oz.
129	Warning decals	

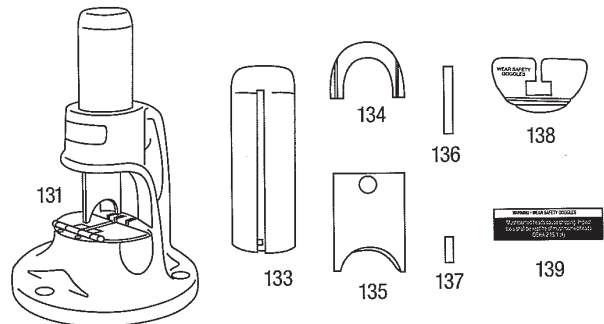

Model 2 (extra heavy duty):

Part no.	Description	Packed Weight
131	Cutter complete	28 lbs.
132	Casting base	21 lbs.
133	Plunger	7 lbs.
134	Die (set)	10 oz.
135	Blade (with pin)	5 oz.

Part no.	Description	Packed Weight
136	Blade pin only	1 oz.
137	Plunger guide pin	1 oz.
138	Guard	3 oz.
139	Warning decals	



1074 Kenran Industrial Dr.  
St. Louis, MO 63137  
Phone: 1-800-381-9968

# HUMCO RIGGING/RATCHETS

## Wire Rope Cutters

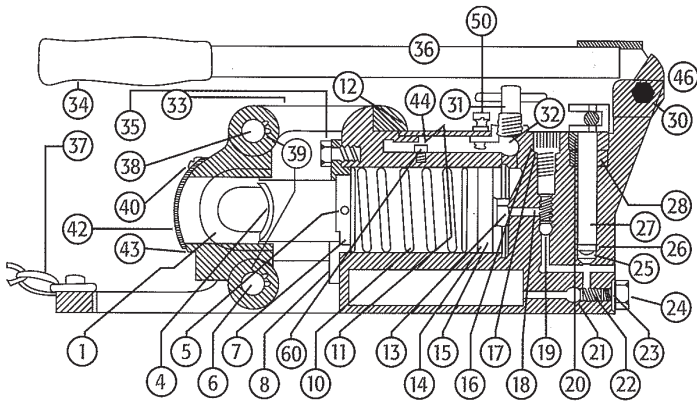

W-075, P-1125, C-1750:

Part no.	Description	Model W	Model P	Model C
1	Die set	W1	P1	C1
4	Blade	W4	P4	C4
5	Blade pin	W5	P5	C5
6	Hinge pin w/#39	W6	P6	C6
7	Ram	W7	P7	C7
8	Ram collar	W8	P8	C8
10	Ram retracting spring	W10	P10	C10
11	Cover plate	W11	P11	C11
15	Ram Cup Leather Retainer	W15	P15	C15
33	Latch	W33	P33	C33
36	Pump handle	W36	P36	C36
38	Latch pin w/ #39	W38	P38	C38
43	Shear blade holder	W43	P43	C43
60	Bypass valve	n/a	P60	C60
62	Overhaul kit	W62	P62	C62

Overhaul Kit includes:

(items listed must be purchased in kit form only)

- |                                    |                           |
|------------------------------------|---------------------------|
| 12 Cover plate screws (3)          | 28 Plunger packing set    |
| 13 Ram Retainer Screw & Lockwasher | 30 Handle hinge bolt      |
| 14 Ram Cup Leather & O-ring        | 31 Release valve retainer |
| 16 Check valve plug                | 32 Release valve          |
| 17 Check valve gasket              | 34 Handle grip            |
| 18 Check valve spring              | 35 Ram collar screws (3)  |
| 19 Ball check valve                | 37 Bail                   |
| 20 Packing nut                     | 39 Snap rings (4)         |
| 21 Ball suction valve              | 40 Guard Screws (2)       |
| 22 Suction valve spring            | 42 Guard plate            |
| 23 Suction valve gasket            | 44 Cover gasket           |
| 24 Suction valve plug              | 46 Lock nut               |
| 25 Plunger packing screw           | 47 Packing nut wrench     |
| 26 Plunger end packing             | 50 Air vent valve         |
| 27 Plunger                         |                           |



Model W-075  
3/4" capacity



Model P-1125  
1 1/8" capacity

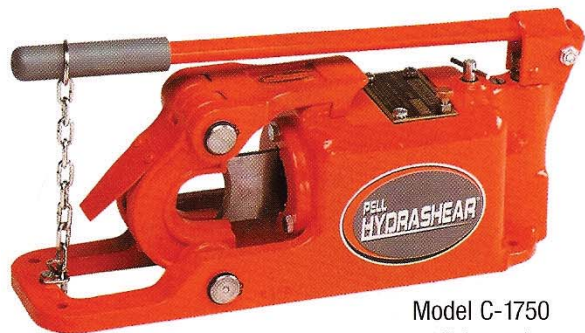

Model C-1750  
1 3/4" capacity

These self-contained hydraulic cable cutters are precision engineered tools designed to give a clean cut with minimum effort. Just pump the handle, no outside power is required. Able to be easily carried, these models are favorites of contractors, rigging lofts and elevator repairmen, and are recommended by wire rope manufacturers worldwide. All three models will operate underwater.



1074 Kenran Industrial Dr.  
St. Louis, MO 63137  
Phone: 1-800-381-9968

# HUMCO RIGGING/RATCHETS

## Wire Rope Cutters



Model POC 2500  
2 1/2" capacity



Model POC 1750  
1 3/4" capacity

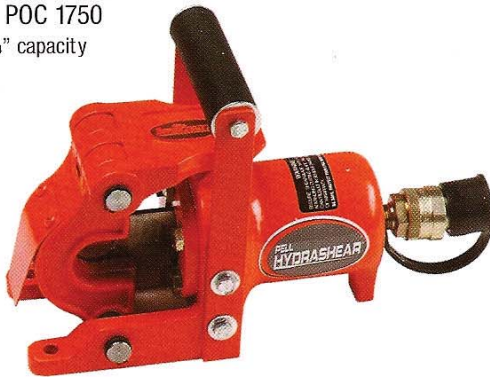

Model POC 1125  
1 1/8" capacity

These models can be activated by any electric, gasoline, hand, battery or air operated hydraulic pump capable of developing 10,000 p.s.i. and having free flow return through the pressure line. The pumps are then hose-connected to the Hydrashear body. Available in three sizes and cutting capacities.

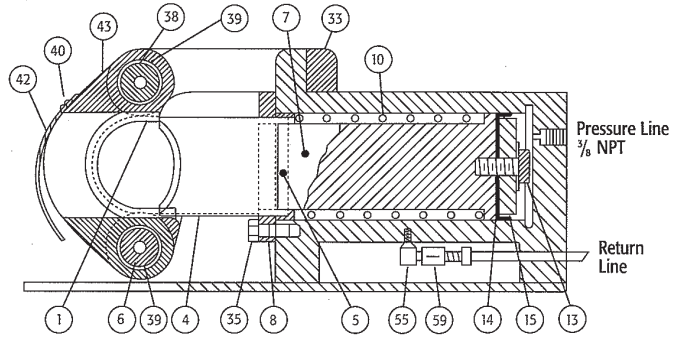

PO C 2500:

Part no.	Description	Part no.	Description
1	Die set	33	Latch
4	Blade	35	Ram collar screw
5	Blade pin	38	Latch pin with #39
6	Hinge pin	39	Snap ring
7	Ram	40	Guard screw
8	Ram collar	42	Guard plate
10	Retracting spring	43	Shear blade holder
13	Ram retainer screw	55	1/4" NPT street elbow
14	Cup leather	59	1/4" NPT directional valve
15	Cup retainer		

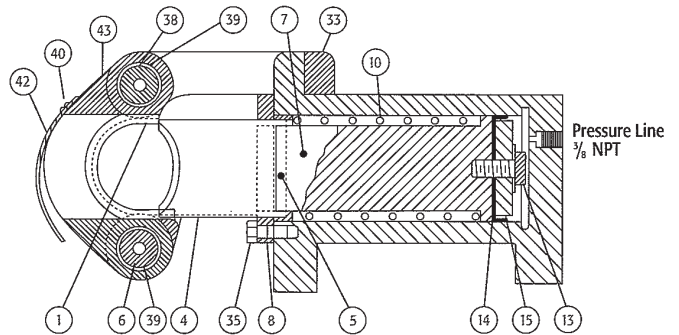

POC 1125 & POC 1750:

Part no.	Description	Part no.	Description
1	Die set	15	Cup retainer
4	Blade	33	Latch
5	Blade pin	35	Ram collar screw
6	Hinge pin	38	Latch pin with #39
7	Ram	39	Snap ring
8	Ram collar	40	Guard screw
10	Retracting spring	42	Guard plate
13	Ram retainerscrew	43	Shear blade holder
14	Cup leather		



1074 Kenran Industrial Dr.  
St. Louis, MO 63137  
Phone: 1-800-381-9968

# HUMCO RIGGING/RATCHETS

## Wire Rope Cutters

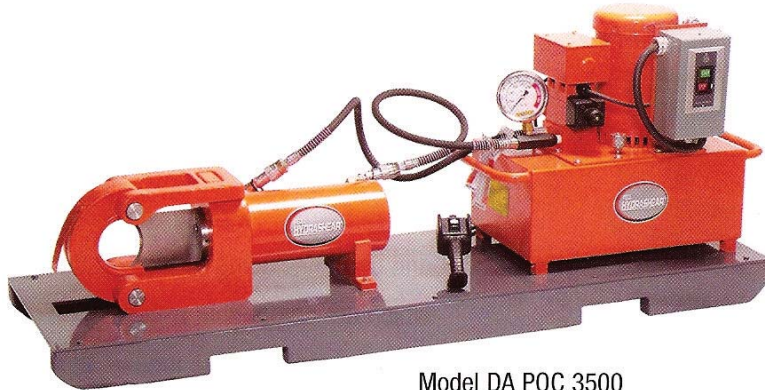

Model DA POC 3500

DA POC 2500 and DA POC 3500:

Part no. 2500	Part no. 3500	Description	Part no. 2500	Part no. 3500	Description
1	1	Die set	45	45	Blade holder
4	4	Blade	48	48	Cylinder locking screws (2)
5	5	Blade pin	49	49	Cylinder support
6	6	Hinge pin	51	51	Cylinder
29	29	Hold down bolts (2)	82	82	Hose set
33	33	Latch	83	83	Base plate
38	38	Latch pin	84	84	Pump
39	39	Snap rings (4)	85	85	Pressure Gauge
40	40	Guard screws (2)			
42	42	Guard			
43	43	Shear blade holder			

Model must be specified when ordering parts

Designed to operate at a maximum pressure of 10,000 psi, the DA POC 3500 has a double-acting 75-ton cylinder that will cut 3 1/2" cable in 40 to 45 seconds

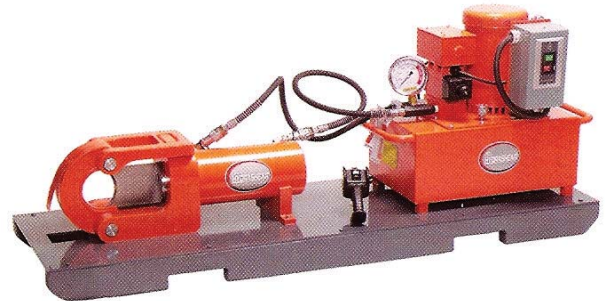

Model D A POC 2500

Designed to operate at a maximum pressure of 10,000 psi, the DA POC 2500 has a double-acting 50-ton cylinder that will cut 2 1/2" cable in 30 to 35 seconds

A double-acting cylinder is powered in both directions for a faster and more positive return.

Both cutters are powered by an electrically driven hydraulic pump 3 HP/3 phase dual voltage motor, 240/460 - 60 Hz.

The DA POC 2500 and DA POC 3500 are sold as a complete unit, including cutting head, base plate, cylinder, pump and hoses.

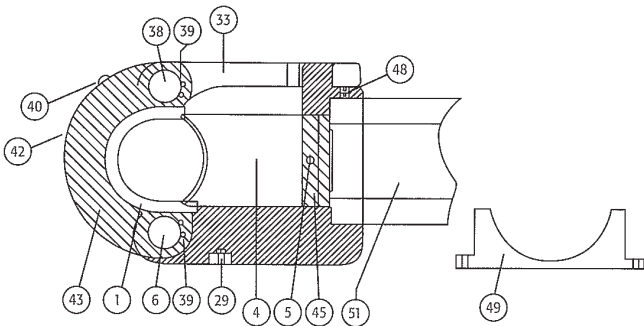

POC 1750 (shown here with pump)



1074 Kenran Industrial Dr.  
St. Louis, MO 63137  
Phone: 1-800-381-9968

# HUMCO RIGGING/RATCHETS

## Wire Rope Cutters



Morse-Starrett stocks a variety of pumps and parts (including hoses and fittings) which are compatible with our power operated tools. Please call Humco about price, availability and specifications.

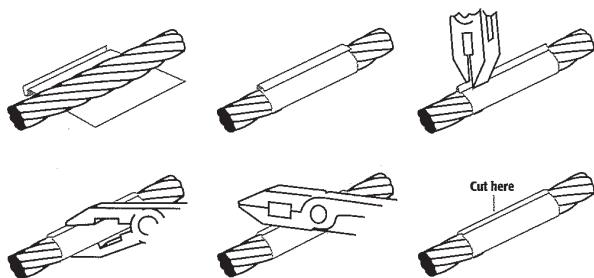
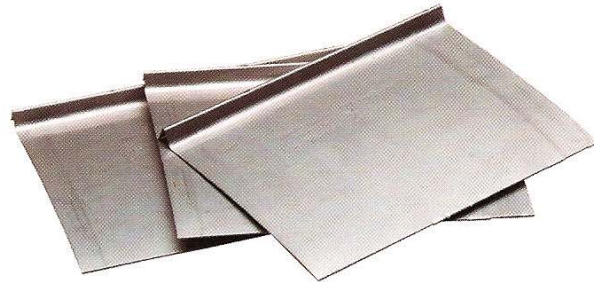

Cable band sizes:

3/16"	9/16"	15/16"
1/4"	5/8"	1"
5/16"	11/16"	1 1/8"
3/8"	3/4"	1 1/4"
7/16"	13/16"	1 3/8"
1/2"	7/8"	1 1/2"

Designed for use with the Morse-Starrett cutter, bands are made of pliable material indented with a groove and lock seam at one edge. Application of the band is simple, requires no special tools and may be made in seconds with an ordinary pair of pliers.

Note: Each rope requires a band of corresponding size. All bands packed and sold in boxes of 50, one size per box.



1074 Kenran Industrial Dr.  
St. Louis, MO 63137  
Phone: 1-800-381-9968

# HUMCO RIGGING/RATCHETS

## Wire Rope Cutters



Model S

### Designed for cutting:

- 1/2" prestressed concrete strand
- 1/2" mild steel round chain
- 5/8" reinforced bar
- 5/8" bolts

Convenient to use at any angle and weighing less than 12 lbs, the Model S can be activated by any electric, gasoline, hand, battery or air operated hydraulic pump capable of developing 10,000 p.s.i. and having free flow return through the pressure line. The front blade can be adjusted to proper cutting clearance after sharpening, and the back blade is fixed.

Please specify if tool will be used for cutting round chain; a modification of the cutting head is required.

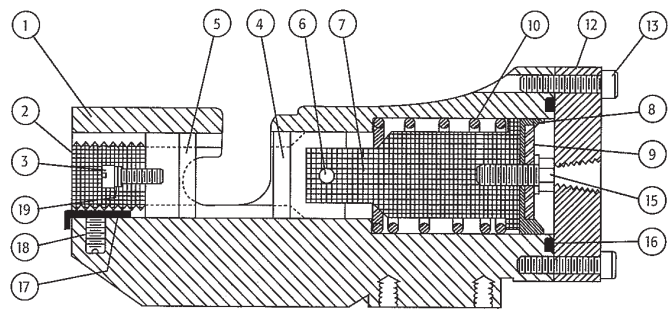

Model S:

Part no.	Description	Part no.	Description
S-2	Adjusting screw	S-10	Retracting spring
S-3	Blade holding screw	S-12	End plate
S-4	Rear blade (moving blade)	S-13	end plate screw
S-5	Front blade	S-15	Ram retainer screw
S-6	Blade pin	S-6	"O" ring
S-7	Ram	S-7	Locking wedge
S-8	Cup leather	S-18	Set screw
S-9	Cup leather retainer	S-19	Spring washers (2)