



1074 Kenran Industrial Dr.
St. Louis, MO 63137
Phone: 1-800-381-9968

HUMCO WIPERS

United Technologies Wiper Systems

WWJ

DESCRIPTION:

Heavy-duty 12-24 volt WWJ windshield wiper series.

CONSTRUCTION:

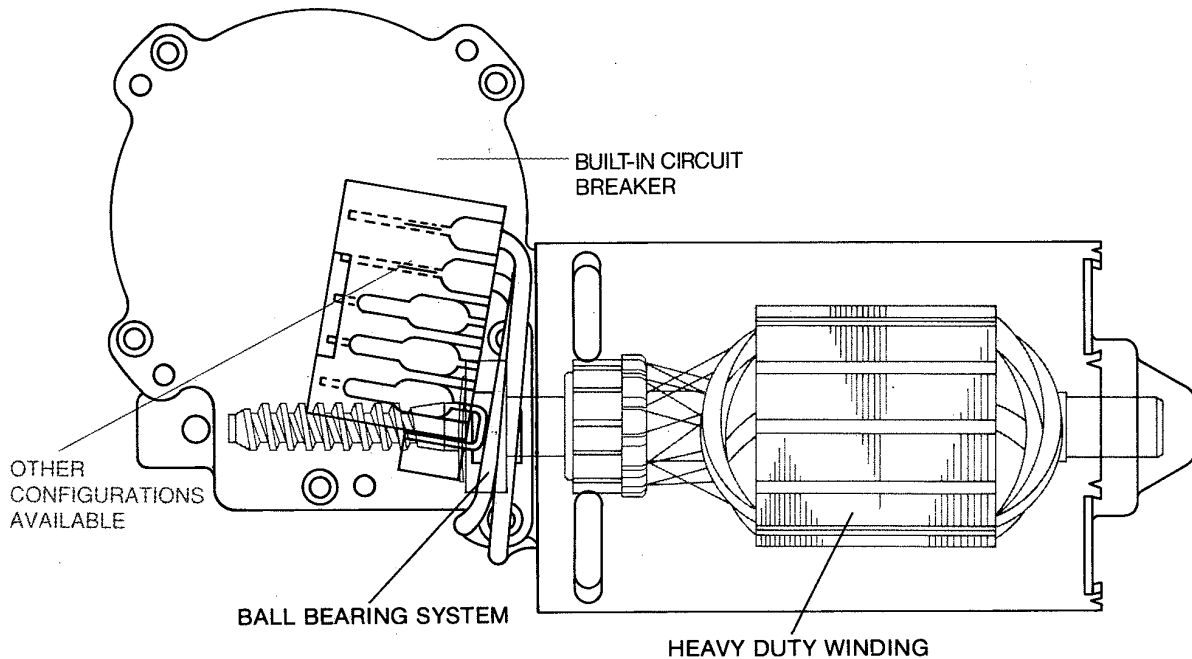
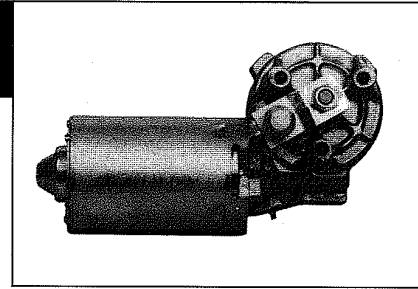

FEATURES:

- high efficiency rotating output shaft
- heavy-duty/lightweight (3.02 lbs.)
- internal circuit breaker
- internal R.F.I. protection available
- coast to park (dynamic park optional)
- 300 in.lb. stall torque
- adjustable park
- 2 speeds
- ball bearing for greater efficiency and smooth operation

APPLICATIONS:

- heavy-duty trucks
- recreational vehicles
- construction equipment
- utility vans
- agricultural vehicles
- school buses



1074 Kenran Industrial Dr.
St. Louis, MO 63137
Phone: 1-800-381-9968

HUMCO WIPERS

United Technologies Wiper Systems

WWJ

WIRING DIAGRAMS

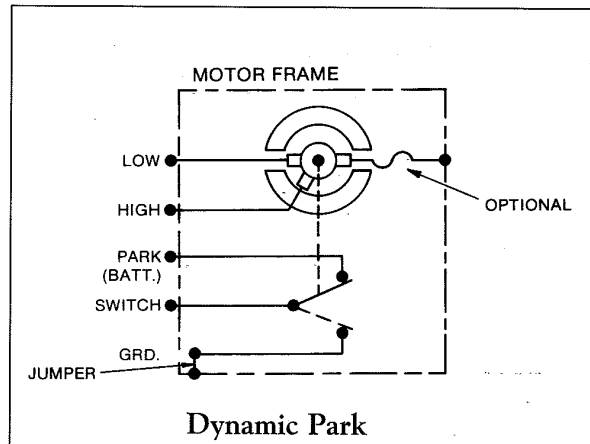
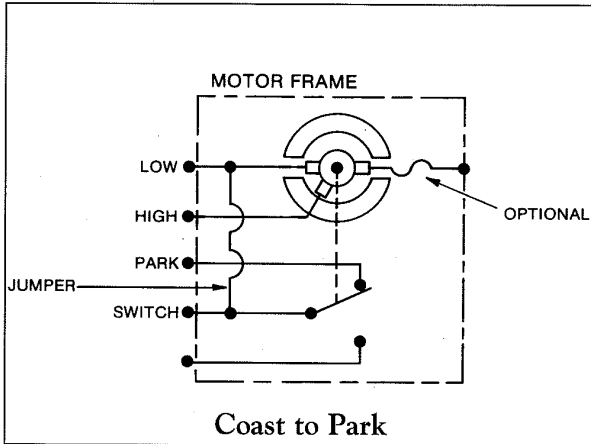

Motors are coast to park standard - to convert to dynamic park, remove the short jumper from the G & S terminals and replace it with jumper number 6259240CB25WJ. The new jumper is plugged into the X terminal on one end and grounded to the gear housing with screw 5980840SC25WJ on the other.

*Mating connector for the WWJ terminal block is 6237440EC25WJ.

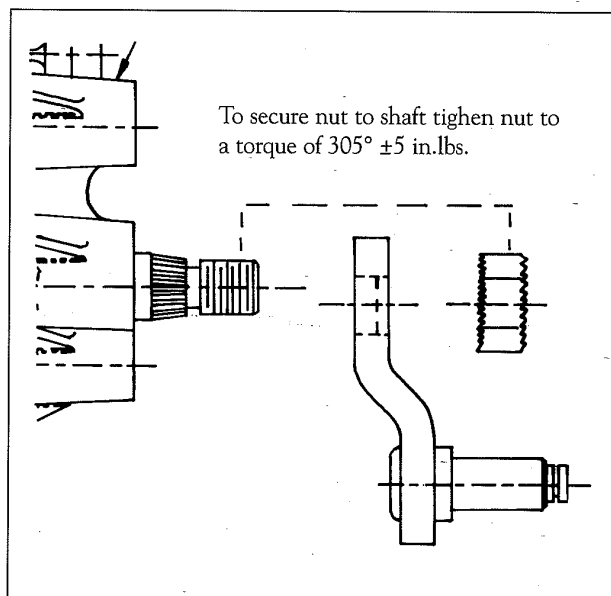
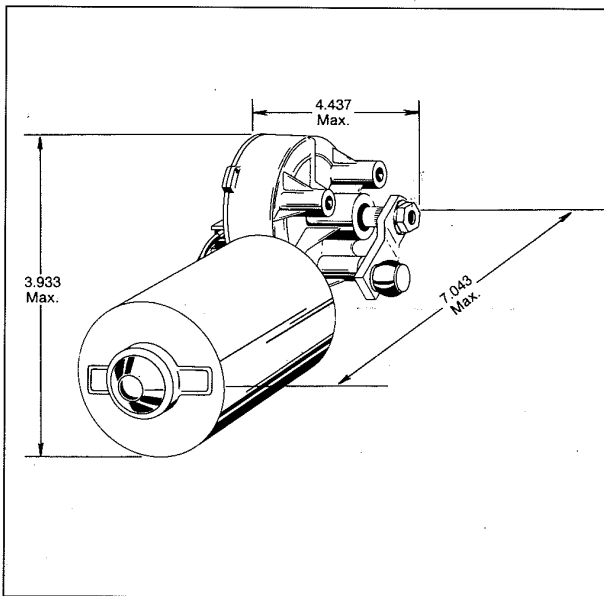

Specifications (Typical Operating)

- stall torque—300 in.lbs.
- voltage—12, 24
- stall current—20 amps, no-load 1 1/2 amps
- weight—3 lbs.
- low speed—approx. 36 rpm
- high speed—approx. 60 rpm
- envelope size (4" x 4 1/2" x 7 1/2")

PERFORMANCE CURVE

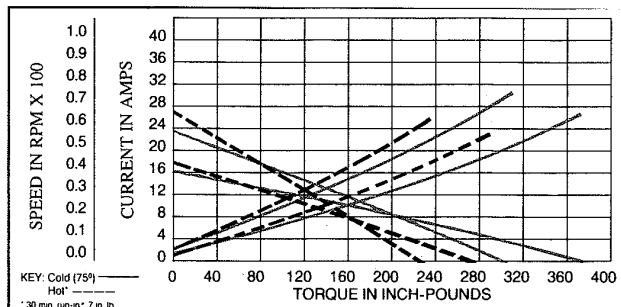



1074 Kenran Industrial Dr.
St. Louis, MO 63137
Phone: 1-800-381-9968

HUMCO WIPERS

United Technologies Wiper Systems

WWJ

A dual installation using one motor with two arms and blades can be custom designed for your specific header or cowl mount application. "Coast to park" automatic parking is standard with "dynamic parking" readily available, should your application require it. Five wipe angles from 68° to 127° can be obtained by using one of two drive arms and selecting the proper pivot arm position. Unitized assembly of the motor, bracket, linkage, and pivot shaft provides built-in oscillating motion and all components for a compact installation.

Although this WWJ system heavy duty wiper is of unitized design, the major components may be ordered individually to permit the most suitable choice of operating voltages, wipe angles, and pivot shaft lengths. When ordering a Wiper Motor Kit for a unitized installation, three numbers are necessary:

1. Motor Kit Number
2. Drive Arm Number
3. Pivot Shaft Number

Use the following charts and diagrams to determine numbers.

Voltage	Motor Kit WWJ	Motor Alone
12	65775-40-MO25WJ	65652-40-MO25WJ
24	65776-40-MO25WJ	65661-40-MO25WJ

Wipe Angle	Pin Position	Connecting Link	Drive Arm WWJ
68°	A	LK721014	6211140LE25WJ
85°	B	LK721014	6211140LE25WJ
93°	A	LK721014	6211240LE25WJ
108°	C	LK721014	6211140LE25WJ
127°	B	LK721014	6211240LE25WJ

Note 1 - Pin Position C cannot be used with 6211240LE25WJ.

Note 2 - For double link single motor application replace 6211140LE25WJ with 6211340LE25WJ, or replace 6211240LE25WJ with 6211440LE25WJ

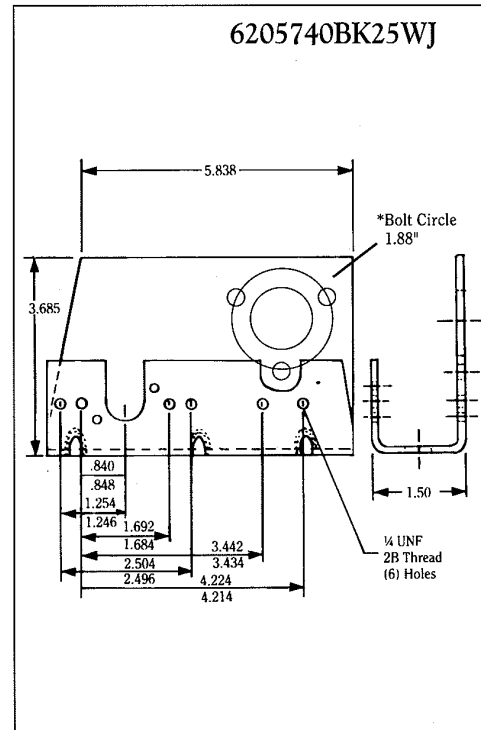
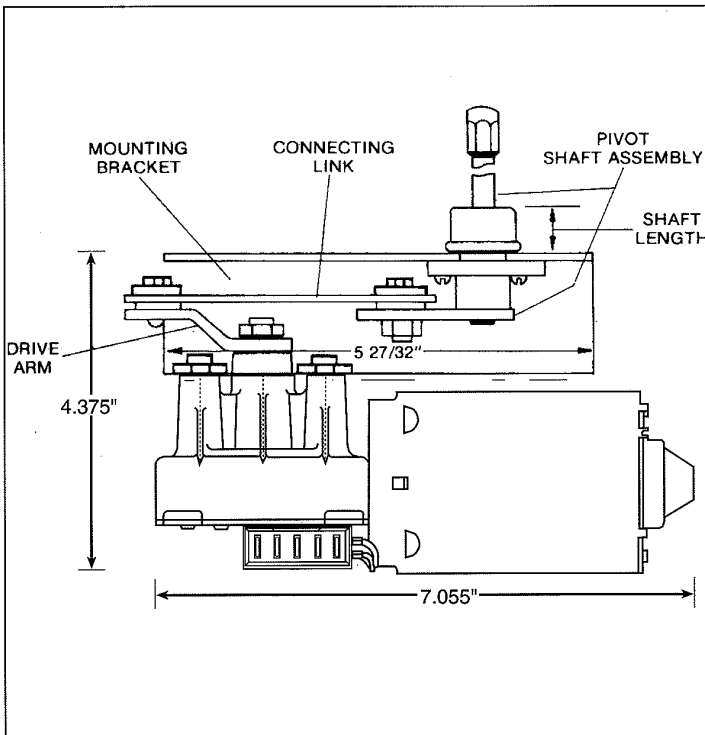



1074 Kenran Industrial Dr.
St. Louis, MO 63137
Phone: 1-800-381-9968

HUMCO WIPERS

United Technologies Wiper Systems

WWJ

UNITIZED SYSTEM COMPONENTS

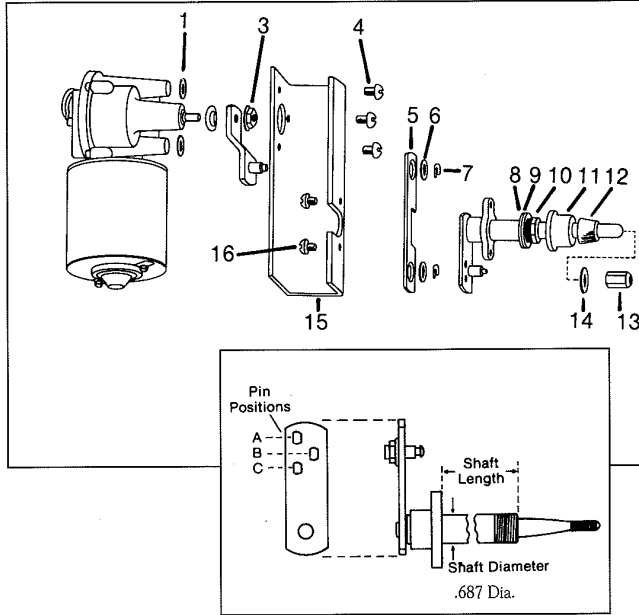

III. No.	Part No.	Qty. Used	Description
1-7&16	62224040GP25WJ	1	Group Part
1	WA 1216*	3	Spacing Washer
3	6787740NT25WJ	1	Nut
4	6266740SC25WJ	3	Fastening Screw
5	LK 721014	1	Connecting Link
6	WA 1654	2	Spacing Washer
7	1781540SP27WC	2	Clip Spring
8	6257340WA25WJ	1	Washer
9	6257440WA25WJ	1	Washer
10	6257740NT25WJ	1	Nut
11	6257240CP25WJ	1	Cap
12	6258040NT25WJ	1	Knurled Driver
13	6257140NT27WC	1	Nut
14	6257840WA27WC	1	Washer
15	6205740BK25WJ	1	Bracket
16	SC1160	2	Screw

*Use only on dual link applications to space motor from bracket.

Service Parts Policy for WWJ

The gear shaft assembly 62547-40-GE25WJ is the only item offered for service of the motor. However, all the necessary items used to make a unitized assembly (Bracket, Drive Arm, Pivot Shaft, etc.) are offered for service. (See above.)

General Re-Work Procedure

To replace the gear it will be necessary to remove the gear cast

1. Drill out 4 bosses which are headed over.
2. Gently pry cover from casting.
3. Re-fasten the cover to the drilled gear housing with screw, SC 3018, (#5-40 UNC-2) using the .104" diameter holes cast in each housing. (Tightening torque should be 90 in.oz. minimum.)

Pivot Shaft Dimensions

Shaft Length	Pivot Shafts
1"	6271540SH25WJ
1.25"	6271140SH25WJ
2"	6271240SH25WJ
3"	6271440SH25WJ

Pivot Shaft Length	Wiper Angle	Pin Pos. on Mtg.	Uses Drive Arm No.	Uses Pivot Shaft No.	12 VOLT		24 VOLT	
					Lt. Hand Park Order Assy. No.	Rt. Hand Park Order Assy. No.	Lt. Hand Park Order Assy. No.	Rt. Hand Park Order Assy. No.
1".25	68°	A	6211140LE25WJ	6271140SH25WJ	6572120MO25WJ	6572220MO25WJ	6575120MO25WJ	6575020MO25WJ
1".25	93°	A	6211240LE25WJ	6271140SH25WJ	6572320MO25WJ	6572420MO25WJ	6575320MO25WJ	6575220MO25WJ
2"	68°	A	6211140LE25WJ	6271240SH25WJ	6572520MO25WJ	6572620MO25WJ	6575520MO25WJ	6575420MO25WJ
2"	93°	A	6211240LE25WJ	6271240SH25WJ	6572720MO25WJ	6572820MO25WJ	6575720MO25WJ	6575620MO25WJ
3"	68°	A	6211140LE25WJ	6271440SH25WJ	6572920MO25WJ	6573020MO25WJ	6575920MO25WJ	6575820MO25WJ
3"	93°	A	6211240LE25WJ	6271440SH25WJ	6573120MO25WJ	6573220MO25WJ	6576120MO25WJ	6576020MO25WJ
1.25"	85°	B	6211140LE25WJ	6271140SH25WJ	6573320MO25WJ	6573420MO25WJ	6576320MO25WJ	6576220MO25WJ
2"	85°	B	6211140LE25WJ	6271240SH25WJ	6573520MO25WJ	6573620MO25WJ	6576520MO25WJ	6576420MO25WJ
3"	85°	B	6211140LE25WJ	6271440SH25WJ	6573720MO25WJ	6573820MO25WJ	6576720MO25WJ	6576620MO25WJ
1.25"	108°	C	6211140LE25WJ	6271140SH25WJ	6573920MO25WJ	6574020MO25WJ	6576920MO25WJ	6576820MO25WJ
2"	108°	C	6211140LE25WJ	6271240SH25WJ	6574120MO25WJ	6574220MO25WJ	6577120MO25WJ	6577020MO25WJ
3"	108°	C	6211140LE25WJ	6271440SH25WJ	6574320MO25WJ	6574420MO25WJ	6577320MO25WJ	6577220MO25WJ

WWJ wipers are designated Right Hand or Left Hand by viewing into the pivot shaft assembly with unitized bracket base down. If the pivot shaft lever (the part with the pin) stops on the left side, it is a Left Hand Park Wiper, likewise, if the pivot shaft lever stops on the right side, it is a Right Hand Park Wiper. This designation does not indicate either right or left hand on the final assembly on a vehicle, but rather applies as a designation for the assembly itself.

For part numbers listed as left hand park in this brochure, the blade will park on the left if the assembly is mounted above the windshield and viewed from inside the vehicle.

THE UNITIZED ASSEMBLIES SHOW IN THE ABOVE TWO CHARTS INCLUDE THE APPROPRIATE DRIVE ARM AND PIVOT SHAFT. HOWEVER, WHEN ONE OF THESE UNITIZED ASSEMBLIES IS UNAVAILABLE, AN EQUIVALENT CUSTOM SYSTEM CAN BE ASSEMBLED BY ORDERING 6361240, FOR 12 VOLT, OR 6362440, FOR 24 VOLT, PLUS THE APPROPRIATE DRIVE ARM AND PIVOT SHAFT.



1074 Kenran Industrial Dr.
St. Louis, MO 63137
Phone: 1-800-381-9968

HUMCO WIPERS

United Technologies Wiper Systems

WWJ - BLADES

(ALL BLADES ARE FLEX TYPE AND COLOR BLACK)

Part No.	Length
5216840BD27WC	12
5216940BD27WC	14
5217040BD27WC	16
5217140BD27WC	18
5217240BD27WC	20

Part No.	Length
5191640BD27WC	22
5214740BD27WC	24
5214840BD27WC	26
5214940BD27WC	28



PANTOGRAPH ADAPTOR KITS

(Pantograph Arms sold separately. (See page 670.)

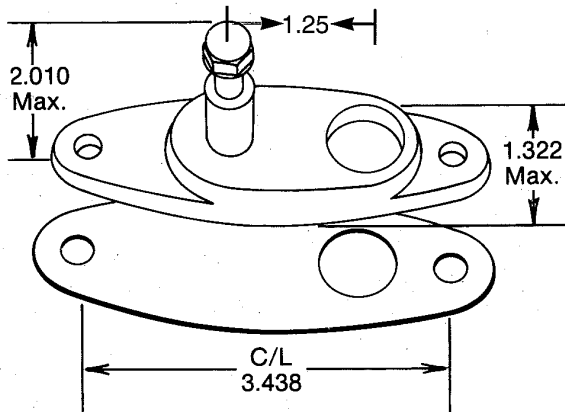

Kit Number	Used with: Pivot Shaft	Center Distance
48519-40-KT27WC	Heavy duty-black	1 1/4"

NOTE - add 3/4" to pivot shaft length to allow for adaptor kit. Max wipe angle is 93°.

SWITCHES

COAST TO PARK		DYNAMIC PARK	
Part	w/o circuit breaker	w/circuit breaker push to wash	w/circuit breaker push to wash
WW1	1398440SW27WC	SW721025A	6505840SW25WJ
Runs 2 motors	4864040SW27WC has push to wash		

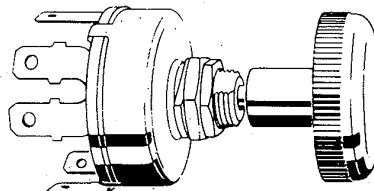
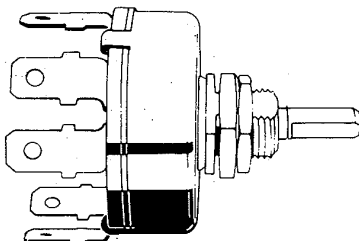



1074 Kenran Industrial Dr.
St. Louis, MO 63137
Phone: 1-800-381-9968

HUMCO WIPERS

United Technologies Wiper Systems

WWJ—ARMS CONNECTING LINKS

DYNA PANTOGRAPH WIPER ARMS

(ALL ARMS ARE BLACK)

MAXIMUM WIPER ANGLE ALLOWABLE IS 93

New Part Number 93° Capability	Old Part Number 85° Capability	Description
6701340LE25WJ	5262840LE27WC	24" wet panto arm
6701440LE25WJ	6255240LE25WJ	26" wet panto arm
6701540LE25WJ	5214140LE27WC	28" wet panto arm
6701640LE25WJ	6452040LE25WJ	28" wet panto arm
6702340LE25WJ	5218340LE27WC	14" dry panto arm
6702440LE25WJ	5218440LE27WC	16" dry panto arm
6702540LE25WJ	5218540LE27WC	18" dry panto arm
6702640LE25WJ	5218640LE27WC	20" dry panto arm
6702740LE25WJ	5218740LE27WC	22" dry panto arm
6702840LE25WJ	5218840LE27WC	24" dry panto arm
6703040LE25WJ	5191740LE27WC	28" dry panto arm

RADIAL WIPER ARMS

(ALL ARMS ARE BLACK)

MAXIMUM WIPER ANGLE ALLOWABLE IS 93

Part Number	Description
5217340LE27WC	12" dry arm
5217440LE27WC	14" dry arm
5217540LE27WC	16" dry arm
5217640LE27WC	18" dry arm
5217740LE27WC	20" dry arm
5217840LE27WC	22" dry arm
5217940LE27WC	24" dry arm
5218040LE27WC	26" dry arm
5218140LE27WC	18" wet arm
5218240LE27WC	20" wet arm
5219140LE27WC	WET KIT
6221840LE27WC	16" wet arm
6221740LE25WC	13" wet arm
6221940LE25WC	22" wet arm
6222040LE25WC	24" wet arm

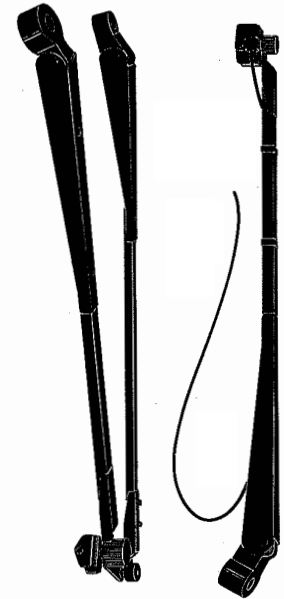

LINKS AND KITS

WWJ System links for non-unitized bracket application. Link No. and distance from hole to center hole.

LK 721014	3.38"
LK 720123	14.64"
LK 721024	8.85"
LK 721026	19.89"
LK 721031	12.80"
LK 721032	32.25"
LK 721033	21.00"
LK 721035-5	19.00"
LK 721038-1	5.75"
LK 721035-7	27.50"
LK 721035-8	22.50"

Note: Custom design linkage systems available on request.

SPRAY NOZZLE KIT 5254440KT27WC

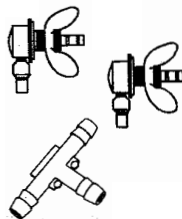

contains—
1-fitting #1305540NZ27WC
*2-spray nozzles #5254540NZ27WC
* Not sold separately

COWL FITTING ASSEMBLY 5036440FI27WC

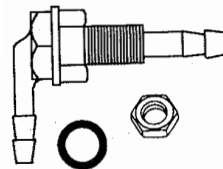

contains—
1-fitting elbow #5036940FI27WC
1-washer-rubber #5036840WA27WC
1-nut NT3-10

WET ARM WASHER KIT 5219140KT27WC

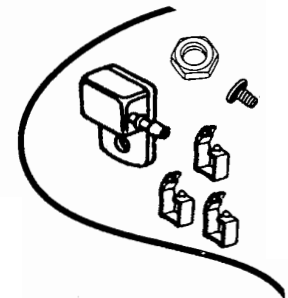

contains—
1-nozzle 5269840NZ27WC
1-tubing no number
1-screw 5269749SC27WC
1-locknut 5269540NT27WC
3-plastic hose clips-no number

670

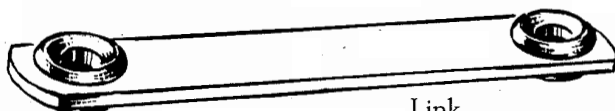

Link

Ball and socket links available for custom applications.



United Technologies Wiper Systems

WWF

DESCRIPTION:

The WWF wiper system provides a totally self-contained oscillating shaft requiring no external linkage. The universal popularity of the WWF is enhanced by the fact that it gives the automotive user marine quality at no extra cost and is consequently ideal for any type of service. Parts exposed to weather are corrosion resistant. An "O" ring between the oscillating shaft and its bearing stud prevents water from entering. A worm gear on the armature shaft turns a large molded drive gear, assuring quiet operation.

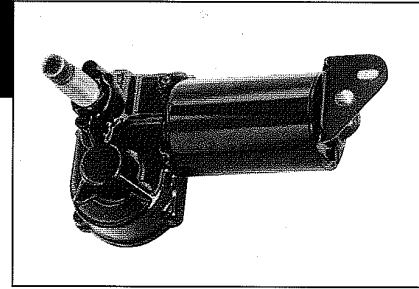

CONSTRUCTION:

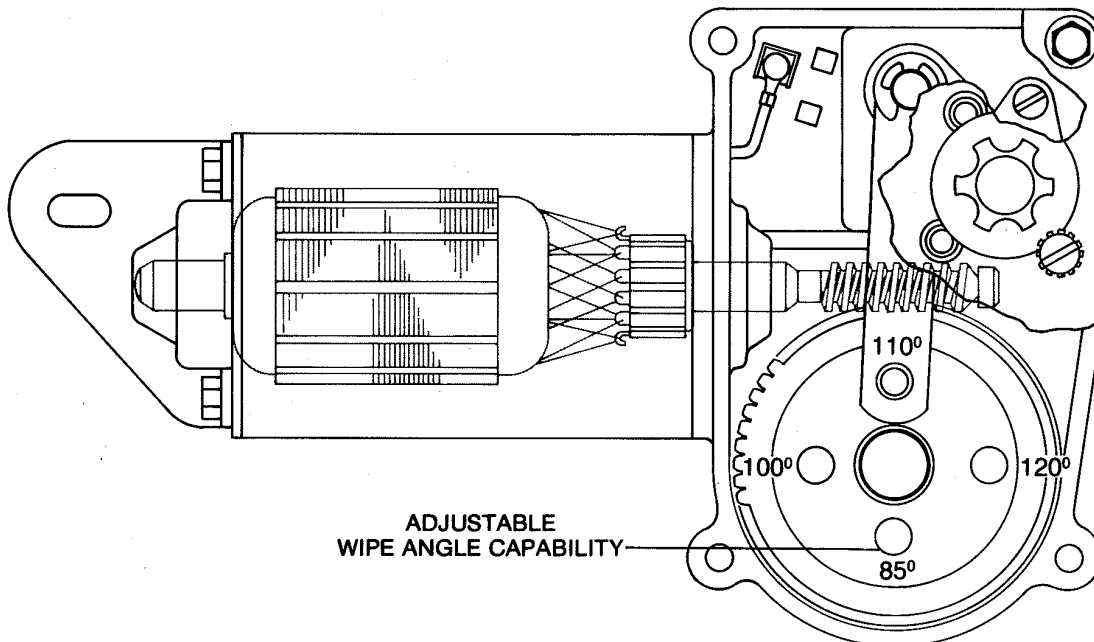

The WWF 12 19-1010, - 1020, and -1030 are set for a 65° wipe angle that is not adjustable. Other WWF wipers are set for a 110° wipe angle that can be adjusted in minutes at the time of installation to 85°, 100°, or 120°. However, quantity orders may be supplied set at the requested angle of 85°, 100°, 110° and 120°. The 19 series of the WWF 12 and 24 is not recommended for marine service because the built-in switch is not sealed.

FEATURES:

- automatic or manual park
- switch in cover plate (some models)
- 2-speed available
- variable wipe angles
 - gear and drive configuration allows customers to adjust wipe angle
 - wipe angle is adjustable to 85°, 100°, 110°, or 120° (65° is available)

APPLICATIONS:

- marine
- agricultural equipment
- rear-window, automobile, motor homes
- off-highway and construction equipment



1074 Kenran Industrial Dr.
St. Louis, MO 63137
Phone: 1-800-381-9968

HUMCO WIPERS

United Technologies Wiper Systems

WWF - TECHNICAL DATA

PERFORMANCE CHARACTERISTICS OF 2" 12V P.M. WWF 2 SPEED MOTOR

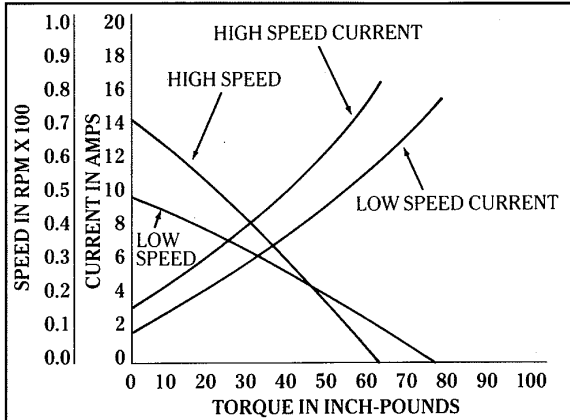

For 12V motors, use 4 amp fuse
For 24 V motors, use 3.5 amp fuse.

WIRING DIAGRAM

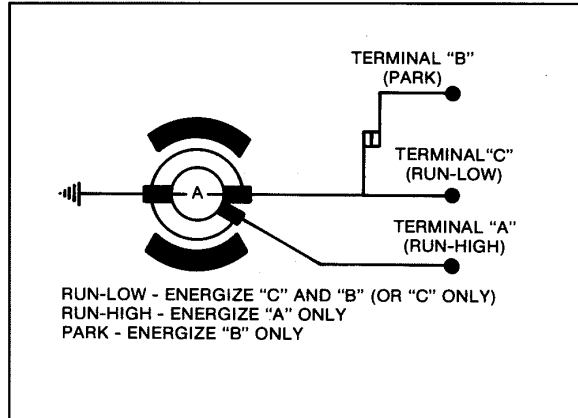

Pivot Shaft

65°	1"	5201540SH20WF
65°	2"	5201640SH20WF
65°	3"	5201740SH20WF
*STD.	1"	1321440SH20WF
*STD.	2"	1321540SH20WF
*STD.	3"	1321640SH20WF

*STD for 85°, 100°, 110°, 120°, wipe angle

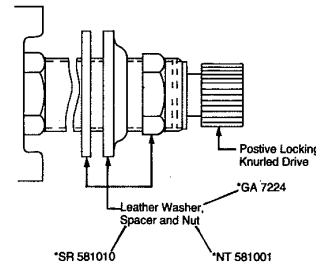
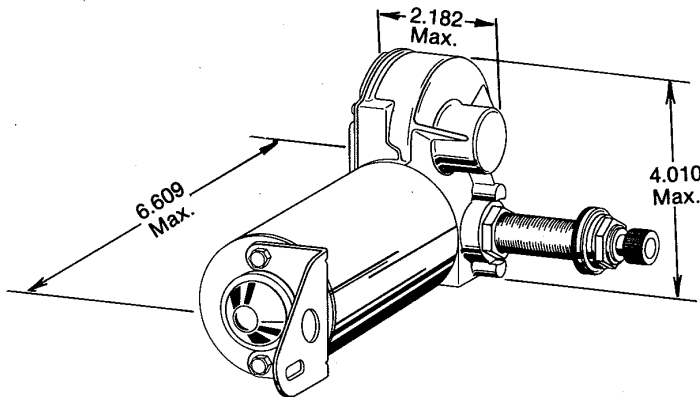

Packaged as a group of loose parts — GP 581003-1

SPECIFICATIONS:

- voltage—12:24
- weight—Approx. 3 lbs.
- current stall— 16 1/2 amp— no load—1 amp
- shaft torque—95 in.lbs.
- speed—60 rpm no load

*CW and/or CCW when viewed from output shaft and with gear box down as shown on page 671.

Part Number Coding System

Example: WWF 12C 1-720

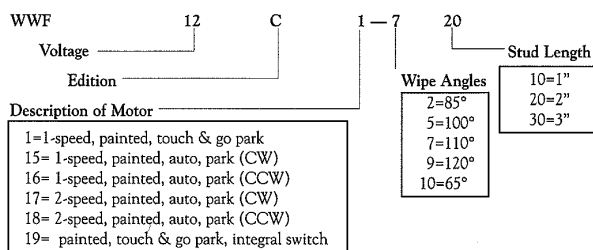

SERVICE PARTS POLICY

Gear, output shaft, and mounting hardware are the only parts offered by service.

Basic service part numbers are GE 581001. Gear for all wipe angles - GP 581003A-1, group part of mounting hardware and internal linkage - LK 581007.



1074 Kenran Industrial Dr.
St. Louis, MO 63137
Phone: 1-800-381-9968

HUMCO WIPERS

United Technologies Wiper Systems

WWF - WIPER BLADES

Ordering (all black paint)

Stud Length	Model & Voltage	1-speed Man.park	1-speed Man.park built in switch	65° built in switch	2-speed auto-park (CCW)	2-speed auto-park (CW)	1-speed auto-park (CCW)	1-speed auto.park (CW)
1"	WWF 12	1-710	19-710	19-1010	18-710	17-710	16-710	15-710
1"	WWF 24	1-710	19-710				16-710	15-710
2"	WWF 12	1-720	19-720	19-1020	18-720	17-720	16-720	15-720
2"	WWF 24	1-720	19-720				16-720	15-720
3"	WWF 12	1-730	19-730	19-1030	18-730	17-730	16-730	15-730
3"	WWF 24	1-730	19-730				16-730	15-730

WWF WIPER ARMS AND BLADES PANTOGRAPH (not stainless steel)

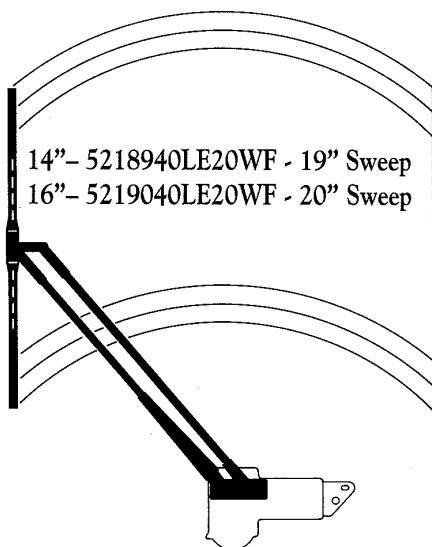

BLADES (not stainless steel)

(For Above Pantograph Arms only)

12" - 5216840BD27WC

14" - 5216940BD27WC

16" - 5217040BD27WC

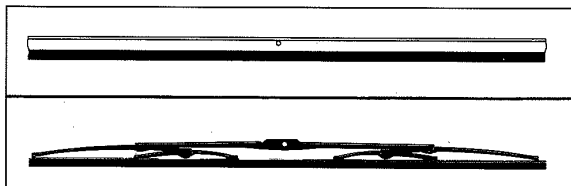

RADIAL (stainless steel)

Part No.	Length	Color
LE 721155	6-10*	Dull Chrome
LE 721156	10-14*	Dull Chrome
LE 581021-12	12	Dull Chrome
LE 581021-14	14	Dull Chrome
LE 581021-16	16	Dull Chrome
LE 581021-18	18	Dull Chrome
LE 581021-20	20	Dull Chrome
5095140LE20WF	15-19*	Black
5095040LE20WF	10.75-15*	Black
LE 581022-1	10.75-15*	Dull Chrome
LE 581022-2	15-19*	Dull Chrome

*Adjustable length

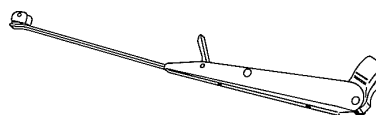

BLADES (stainless steel)

Part No.	Type	Length	Color
BD 721020-12	Flat	12	Dull Chrome
BD 721020-14	Flat	14	Dull Chrome
BD 721011-14	Flat	14	Dull Chrome
BD 721011-16	Flat	16	Dull Chrome
BD 721011-18	Flat	18	Dull Chrome
BD 721011-20	Flat	20	Dull Chrome
BD 721013-14	Flat	14	Dull Chrome
BD 721013-16	Flat	16	Dull Chrome
BD 721013-18	Flat	18	Dull Chrome
BD 721013-20	Flat	20	Dull Chrome
1818240BD27WC	Flex	20	Black
4762740BD27WC	Flex	12	Black
4883240BD27WC	Flex	14	Black
5073240BD27WC	Flex	16	Black
5095240BD27WC	Flex	14	Black
5127740BD27WC	Flex	18	Black



1074 Kenran Industrial Dr.
St. Louis, MO 63137
Phone: 1-800-381-9968

HUMCO WIPERS

United Technologies Wiper Systems

WWF - ACCESSORIES & KITS

SWITCHES

Part	Switch 12 & 24 volt
WWF	1398440SW27WC

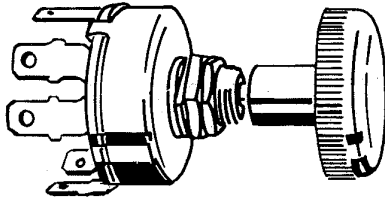

Arm & Blade Capabilities

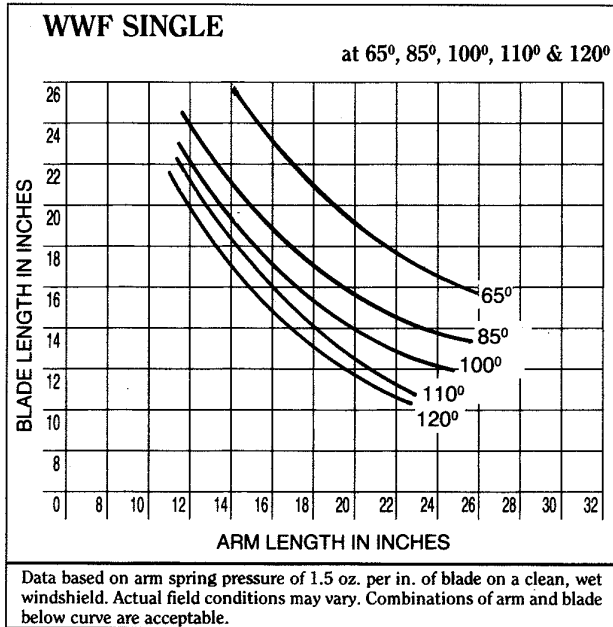

RESERVOIR KITS

8

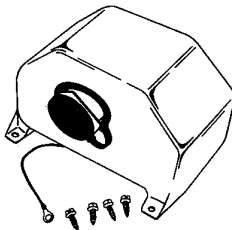

1256240KT27WC

Height—7.20"
Depth—5.50"
Width—5.20"

contains—
1—70 oz. canister
4—screws

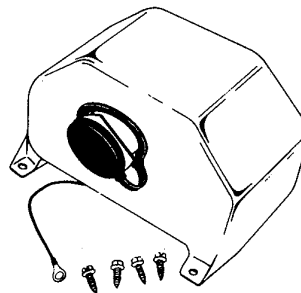

5040640KT27WC

Height—7.52"
Depth—5.51"
Width—9.45"

contains—
1—140 oz. canister
4—screws

INSTALLATION - Use 1/8" I.D. tubing routed from nozzle on motor to "T" fitting, and from there to each spray nozzle. The amount of tubing required will depend on the placement of the washer bottle and spray nozzles. This tubing is NOT available from Motor Systems.

WWF WIPER MOTOR COSMETIC COVER



The ABS material black two-piece cosmetic cover (Part #52312-40KT20WF) with ultra violet inhibitors will add protection from the elements if the motor is mounted in an exposed area, and improve the appearance of the application.



1074 Kenran Industrial Dr.
St. Louis, MO 63137
Phone: 1-800-381-9968

HUMCO WIPERS

United Technologies Wiper Systems

WWC - GEARED ACTUATOR

DESCRIPTION:

A weight of 3.75 lbs. with a steel gear, hardened shaft and rugged construction. Pound for pound, it is more powerful and draws less current than many comparable motors.

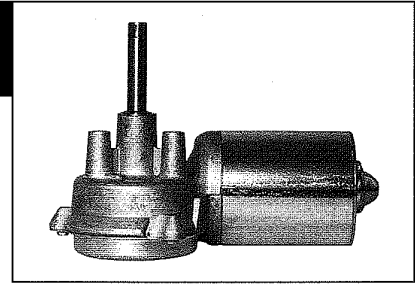

CONSTRUCTION:

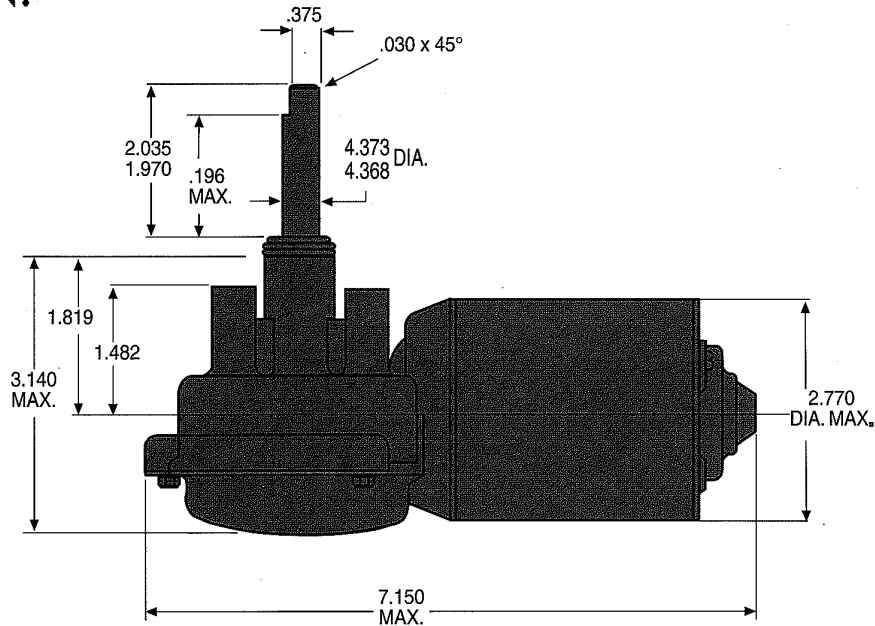

APPLICATIONS:

- wheel chair lift
- feed mixer
- anchor lift
- fertilizer dispenser
- macerator pump
- boat trailer actuator
- satellite dish positioner

PERFORMANCE CURVES

12 VOLT
0244229MO27RM

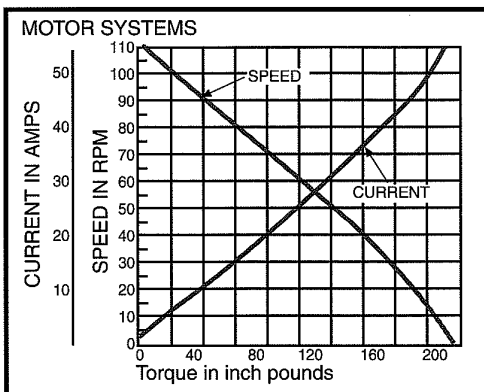

24 VOLT
4870628MO27RM

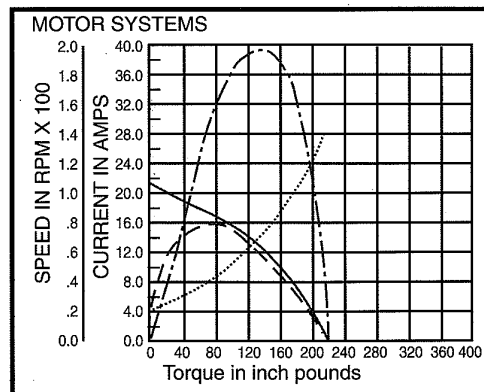

SPEED —————
CURRENT
EFFICIENCY - - - - -
POWER - - - - -