

redFox Conventional Sewage Tank Unit

redFox Conventional STU

Offshore Platforms & Land Uses
USCG/IMO Certified Type II MSD

redFox Model Offshore Platforms	Persons Black Water	Persons Black & Gray Water
RF-200-C	10	4
RF-350-C	18	7
RF-500-C	25	10
RF-750-C	38	15
RF-1000-C	50	20
RF-1500-C	75	30
RF-2000-C	100	40
RF-2500-C	125	50
RF-3000-C	150	60
RF-3500-C	175	70
RF-4000-C	200	80
RF-4500-C	225	90
RF-5000-C	250	100
RF-5500-C	275	110
RF-6000-C	300	120
RF-6500-C	325	130
RF-7000-C	350	140
RF-7500-C	375	150
RF-9000-C	450	180
RF-12000-C	600	240

redFox Model Land Applications*	Persons Black Water	Persons Black & Gray Water
RF-200-C	6	3
RF-350-C	10	5
RF-500-C	15	8
RF-750-C	22	11
RF-1000-C	29	15
RF-1500-C	44	22
RF-2000-C	58	29
RF-2500-C	73	36
RF-3000-C	87	43
RF-3500-C	100	50
RF-4000-C	116	58
RF-4500-C	129	65
RF-5000-C	143	72
RF-5500-C	157	79
RF-6000-C	172	86
RF-6500-C	186	93
RF-7000-C	200	100
RF-7500-C	214	107
RF-9000-C	257	126
RF-12000-C	343	172

* Designed to meet typical land discharge applications; your discharge limit may vary. Larger models available.

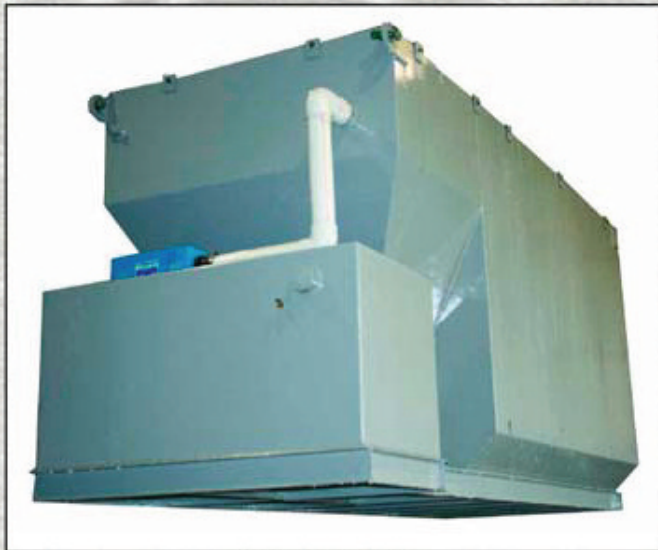

APPLICATIONS:

- Facilities fixed and temporary
- Drilling camps - portable and fixed
- Fixed offshore - inshore platforms
- Remote locations

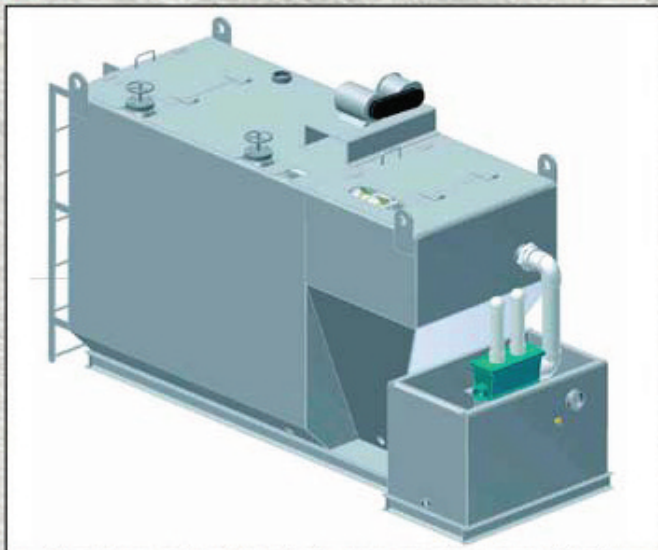

The Conventional model sewage unit is specifically designed for fixed offshore platforms and land based installations. Using the extended aeration process, the unit is portable and easy to install and operate.

The structure and components of **redFox Environmental** units are built for a 20 year service life in the harshest conditions. Some of the first units we ever built are still in operation.



redFox Fox-Pac Marine Sanitation Device

redFox Fox-Pac (MSD)

Marine Vessels & Offshore Platforms
 USCG/IMO Certified Type II MSD

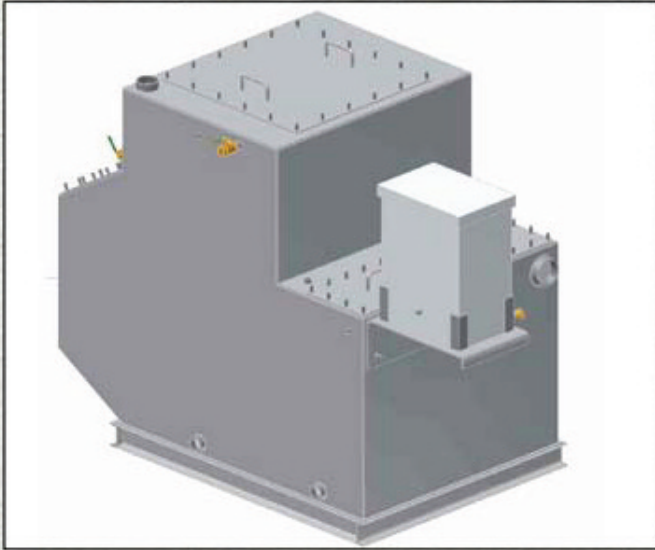

The **Fox-Pac** is designed primarily for marine vessels and fixed platforms that have limited space and weight capacity for a sewage process system.

The **Fox-Pac** is smaller and less costly than our standard marine units. In order to produce this scaled down version, retention time was reduced and the gravity separation process was combined with a high-rate biological aerobic filtration process with two treatment tanks.

redFox Model Offshore Platforms	Persons Black Water	Persons Black & Gray Water
RF-50-FP	3	2
RF-200-FP	10	5
RF-350-FP	18	10
RF-500-FP	25	14
RF-750-FP	38	21
RF-1000-FP	50	28
RF-1500-FP	75	42
RF-2000-FP	100	57
RF-2500-FP	125	70

Fox-Pac Benefits:

- Crew Sizes from 1 To 125
- 50 to 2,500 GPD
- USCG and IMO approved MSD Type II
- Low maintenance
- Low power/utility consumption
- Can be retrofitted into an existing holding tank
- Self-sustaining in fresh or saltwater
- No costly chemicals involved
- No internal moving parts
- Standard configurations or custom designed to meet space limitations





1074 Kenran Industrial Dr.
 St. Louis, MO 63137
 Phone: 1-800-381-9968

redFox Fox-Pac Fiberglass Marine Sanitation Device Models

Fox-Pac Fiberglass MSD Models

Marine Vessels & Offshore Platforms
 USCG/IMO Certified Type II MSD

The **Fox-Pac** Fiberglass MSD is available in three different models and is ideally suited for small vessel applications in the marine and pleasure craft industry. It follows the same proven wastewater treatment principles as the original **Fox-Pac**. The only difference between the original **Fox-Pac** Models and the Fiberglass **Fox-Pac** Models are that they are fabricated of fiberglass instead of metal.

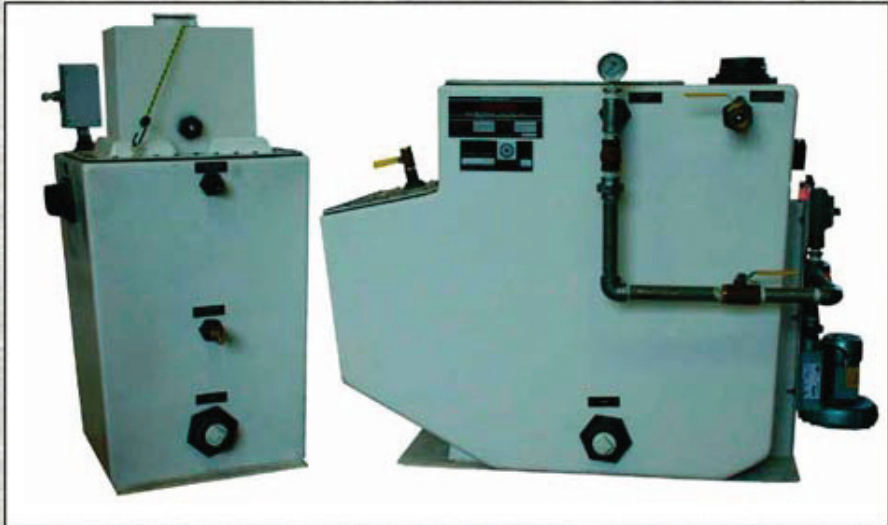

Features	redFox	Fast	Owens	Seahorse
Fiberglass Construction	✓			
Solids Handling Discharge Pump	✓			
316 Stainless Steel Piping	✓			
Light Weight Construction	✓			

redFox Model #	Persons Black Water	Persons Black & Gray Water
Model RF-50- FP-FG	1 to 3	2
Model RF-200- FP-FG	1 to 10	5
Model RF-350- FP-FG	1 to 18	10

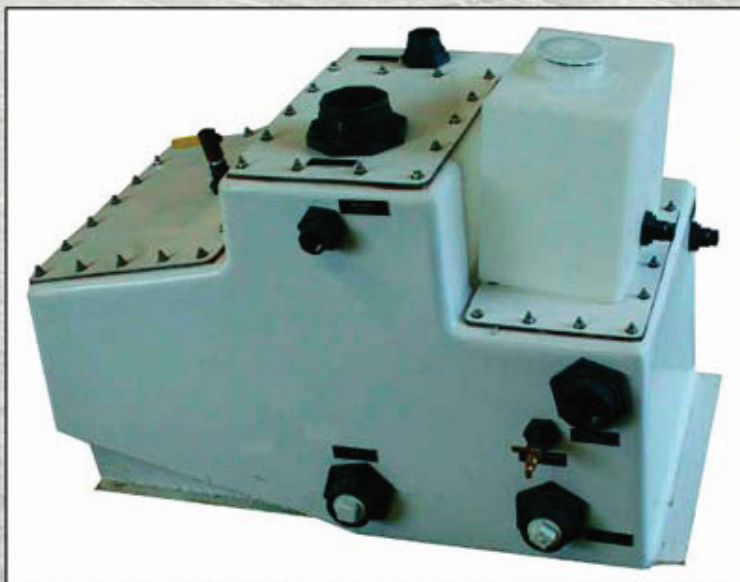

- Meets all USCG and IMO regulations for MSD Type II
- Light weight—ideal for retrofits
- Discharge pump is a solids handling pump
- Operation is continuous in fresh or saltwater
- No costly chemicals involved
- No hot-work / welding for repairs



1074 Kenran Industrial Dr.
 St. Louis, MO 63137
 Phone: 1-800-381-9968

redFox Standard Marine Sanitation Device

redFox Standard Marine (MSD)

Marine Vessels & Offshore Platforms
 USCG/IMO Certified Type II MSD

The first sewage unit given US Coast Guard approval, this model is the original marine sewage treatment system which all other systems are designed to meet.



redFox Model Offshore Platforms	Persons/ Black Water	Persons/ Black & Gray Water
RF-100-M	5	2
RF-200-M	10	4
RF-350-M	18	7
RF-500-M	25	10
RF-750-M	38	15
RF-1000-M	50	20
RF-1500-M	75	30
RF-2000-M	100	40
RF-2500-M	125	50
RF-3000-M	150	60
RF-3500-M	175	70
RF-4000-M	200	80
RF-4500-M	225	90
RF-5000-M	250	100
RF-5500-M	275	110
RF-6000-M	300	120
RF-7500-M	375	150
RF-9000-M	450	180

The Marine model offers these benefits:

- Applicable for processing 100 to 9,000 gal/day
- Crew sizes from 2 to 450
- USCG/IMO Certified Type II MSD
- Offered in standard configurations or custom designed special configuration to meet the customer's specifications and space limitations
- Low maintenance—few moving parts and requirements for maintenance. If maintenance or repairs become necessary, no special tools are required
- Low power/utility consumption
- No odor
- Option of a chlorine injection pump
- Operates with fresh or saltwater

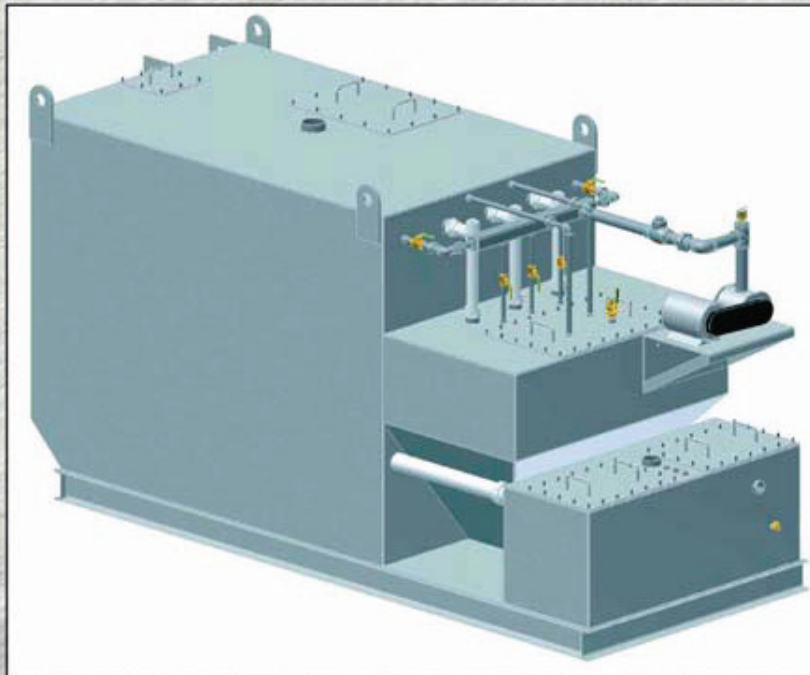

redFox® Vacuum Collection Holding Systems (VCHT)

redFox® Vacuum Collection Holding Systems (VCHT)

redFox® VCHT systems are made with proven technology and the highest quality components.

redFox® VCHT systems are low maintenance and operator friendly.

redFox® VCHT systems are flexible and can be designed in many different variations. The most popular models are eductor systems and vacuum pump systems.

redFox® VCHT systems can be stand alone or integrated into the sewage treatment tank. When integrated, the VCHT enhances sewage treatment thus making the sewage treatment system smaller.

redFox® engineering department can provide custom designed tanks for the VCHT system to fit the customer's design and space requirements.



TOUGH ENOUGH FOR THE US NAVY
redFox® VCHT for T-AKE Class Vessel



redFox® VCHT systems are advantageous by design

- High velocity discharge prevents line clogging
- Small diameter collection piping (1-1/4" to 4") reduces weight, installation and maintenance costs
- Ability to collect wastewater in situations where the water must go up to accommodate piping constraints
- Conserves water consumption for installations with limited water supply



1074 Kenran Industrial Dr.
 St. Louis, MO 63137
 Phone: 1-800-381-9968

redFox Cajun Crusher™

redFox Cajun Crusher™

Trash Compactors

The **redFox Environmental** Cajun Crusher™ is specifically engineered to perform under the rigorous demands placed on equipment operating in the marine and industrial environment. High performance levels and product dependability demanded of all **redFox Environmental** products are built into every model. The **redFox Environmental** Cajun Crusher™ line is designed to deliver trouble-free service, with continuous operation and normal routine maintenance. With an estimated life expectancy of 20 years, the **redFox Environmental** Cajun Crusher™ will also deliver true economy and value.

- Fabricated to withstand heavy loads and constant use
- Components are routed to afford maximum safety
- Personnel controls are housed in explosion-proof panel
- Compaction force 26,000 lbs (11793 kg)
- Hydraulic operating pressure 1,500 psi (103 bar)
- Sound pressure 77 dB
- The motors and compacting cylinder are protected with a full hood. No other manufacturer provides this safety feature.



12 ft³ Model	30 ft³ Model	40 ft³ Model	50 ft³ Model
Length: 4'-0" Width: 3'-10" Height: 7'-1" Weight: 2,000 lbs.	Length: 7'-0" Width: 4'-6" Height: 8'-3" Weight: 3,800 lbs.	Length: 7'-10½" Width: 5'-2" Height: 8'-9" Weight: 4,000 lbs.	Length: 8'-8" Width: 5'-4" Height: 9'-9" Weight: 4,200 lbs.

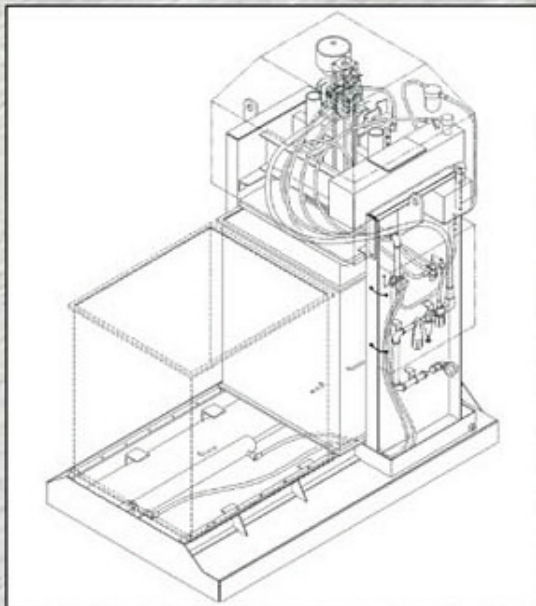

The Cajun Crusher™ is available in (4) models: 12 ft³, 30 ft³, 40 ft³ and 50 ft³. All models are offered with the options of electric over hydraulic or pneumatic over hydraulic.

OUR COMPACTORS CAN BE USED TO COMPACT WASTE, CRUSH DRUMS AND FILTERS.

redFox "Actana" Waterflash Toilets

redFox "Actana" Waterflash Toilets

Flexibility is the best feature of the Waterflash toilet

The result of 40 years of experience, the Waterflash toilet is designed to pump the wastewater 15' vertically and 150' horizontally.

The sewage treatment unit can be located at the same level or above the toilet.

- Quiet operation
- Low water consumption—2 Liters
- Easy and rapid installation
- Reversible operation
- Self-cleaning centrifugal turbine nylon vanes

This eliminates the need for gravity feed sewage discharge lines

Available in 220, 110 AC - 12, 24 DC



Silent and Smooth

waterFox® Sewage Macerator

The new **waterFox**® macerator is designed for the offshore platform which does not require the sewage treatment unit. Regulations specify that waste solids must be no more than 1" in size. The **waterFox**® macerator operates using pressurized water from the platform fire pump or other source to hydraulically rip the solids apart to ¼ inch or smaller. Simply connect the **waterFox**® inline to the existing sewage line and the unit is ready to operate.

waterFox® FEATURES:

- Single frame construction
- Schedule 80 piping
- Oversized back plates
- Patent nozzles
- No moving parts
- No electricity required
- No maintenance needed





1074 Kenran Industrial Dr.
St. Louis, MO 63137
Phone: 1-800-381-9968

redFox Environmental Cleaners

redFox Environmental Cleaners

redFox Environmental supplemental chemicals and cleaners

redFox Environmental offers a complete line of supplemental products to enhance your sewage treatment system's performance. The supplemental products work with the unit to ensure the best water possible.

Supplemental and chemical products

- **redFox** Bacteria Tablets
- **redFox** Concentrate
- **redFox** M12 Nutrient Feed
- **redFox** Chlorine Test Kit
- **redFox** Chlorine Tablets
- **redFox** Test Kit



It is important to the health of **redFox Environmental** sewage treatment systems to use nontoxic, environmentally-safe, ph-neutral cleaning products. **redFox Environmental** offers specialized cleaning products designed to work fast and enhance your system.

JANITORIAL PRODUCTS

- **redFox** General All Purpose Cleaner (Ready to Use)
- **redFox** All Purpose Bathroom Cleaner
- **redFox** Automatic Dishwashing Powder
- **redFox** Liquid Dish Detergent
- **redFox** Laundry Detergent
- **redFox** Multi-Purpose Heavy Duty Cleaner/Degreaser
- **redFox** Heavy Duty Degreaser Concentrated
- **redFox** Floor Cleaner
- **redFox** Foaming Acid Cleaner (Ready to Use)

