



1074 Kenran Industrial Blvd
 Saint Louis, MO 63137
 Phone: (800) 381-9968

HUMCO Pumps

AMT General Use Pumps



Model 2P5XHR



High Pressure
 Hose Kit 55-338

2" Engine Driven Portable High Pressure Pumps

- **Cast Aluminum Construction**
- **EPDM/EPR Mechanical Seals**
- **Optional Viton® Seal and Elastomers Available**
- **2" Cast Iron Suction & Discharge Male NPT Port Sizes**
- **Maximum Flow up to 130 GPM**
- **Maximum Head up to 108 PSI**
- **Maximum Lift to 26 Ft.**
- **One Tool Serviceability**
- **Utilized for Fire Protection or Irrigation**
- **Discharge Port Rotates in 90° Increments**
- **Engine Options: Honda, Briggs & Stratton Gasoline or Hatz Diesel Engines**
- **Optional High Pressure Hose Kit and Wheel Kit Available**

IPT 2" Engine Driven Portable High Pressure pumps are cast aluminum construction with cast iron volute and male NPT ports. Pump applications include fire protection and irrigation. These pumps are available with a wide choice of standard and heavy duty gasoline or diesel fueled engines. These pumps feature high efficiency closed cast aluminum impeller. All models come equipped with EPDM/EPR elastomers and seals. Most models include a heavy duty steel roll frame.

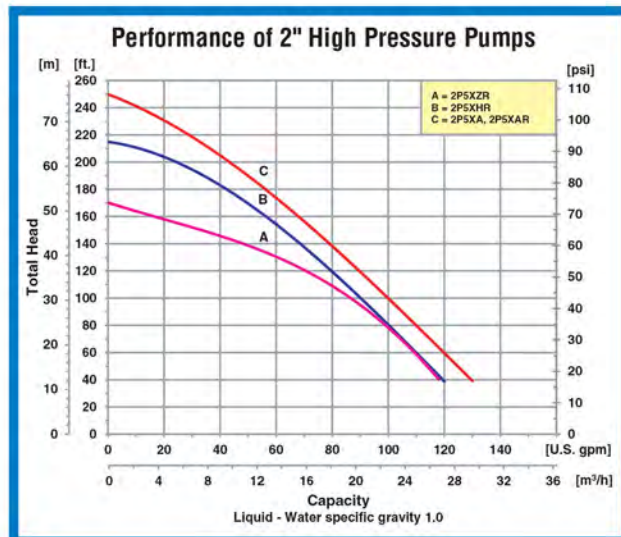

IPT ENGINE DRIVEN HIGH PRESSURE PUMPS



400 Spring Street • Royersford, PA 19468 USA

www.amtpump.com • 888-amt-pump (268-7867)

For use with nonflammable liquids compatible with pump component materials. Viton® and Teflon® are registered trademarks of E. I. DuPont.

FIRE-3



Engine Driven Portable High Pressure Pumps

Pump Dimensional & Specification Data

Model	Curve	Driver	Seal Type & Elastomer/Faces	Tank Size (Gal/Ltr)	Run Time (Hr.)	Mounting	Ship Wt. (Lbs.)
2P5XA	C	Briggs & Stratton Vanguard [▲]	EPDM/EPR/CAR/CER	0.87 / 3.3	1.3	Handle	70
2P5XAR	C	Briggs & Stratton Vanguard [▲]	EPDM/EPR/CAR/CER	0.87 / 3.3	1.3	Roll Cage	90
2P5XHR	B	Honda GX160 [▲]	EPDM/EPR/CAR/CER	0.82 / 3.1	2.8	Roll Cage	90
2P5XZR	A	Hatz Diesel 1B20	EPDM/EPR/CAR/CER	0.79 / 3.0	2.7	Roll Cage	110

Construction: Cast Aluminum with Cast Iron Components

▲ Oil Alert Included

5/8 Threaded Kit (Single)

Model	Seal Type & Elastomer/Faces	Mounting	Ship Wt. (Lbs.)
2P5X	EPDM/EPR/CAR/CER	Handle	35

2" High Pressure Hose Kit

Model	Ship Wt. (Lbs.)
55-338	40

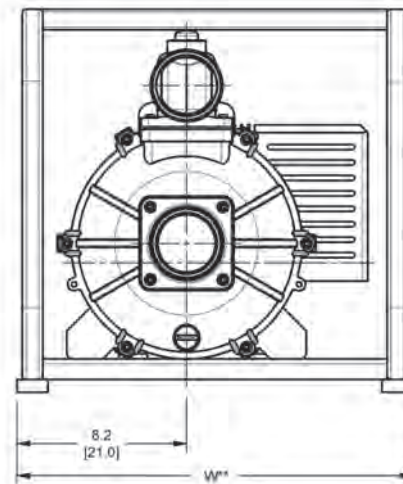
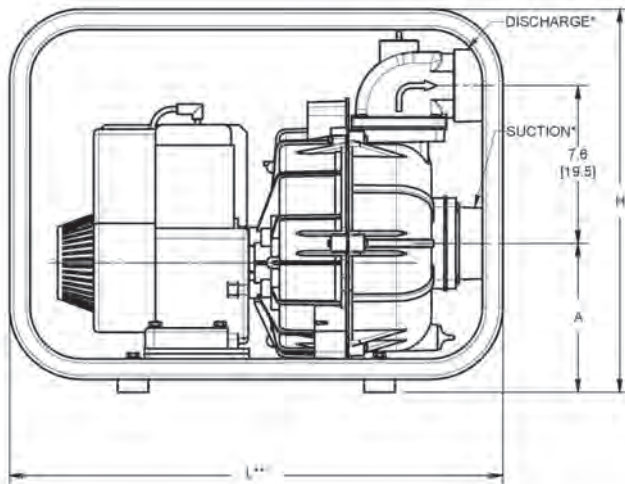

Model	HP Class ♦	SUC*	DIS*	L**	W**	H
2P5X	5 HP	2	2	24.0 [60.9]	19.2 [48.9]	18.6 [47.3]

Gasoline Models	HP Class ♦	A
2P5X	5 HP	7.4 [18.7]

Diesel Models	HP Class ♦	A
2P5XZR	5 HP	7.9 [20.0]

♦ HP Class represents market category and is not intended to define actual horsepower.

(*) Standard NPT (Male) pipe thread.

(**) This dimension may vary due to engine manufacturer's specifications.

NOTE: Dimensions are in inches (centimeters) and have a tolerance of ± 1/8".

Standard Features

- Aluminum Closed Impeller and Cast Iron Volute—Die Cast Aluminum Pump
- Large Pump Casing Increases Capacity
- Built-in Check Valve for Fast Priming
- Removable/Replaceable Cast Iron Suction & Discharge Flanges
- Discharge Port Rotates in 90° Increments
- EPDM/EPR Seal with Carbon and Ceramic Faces with Optional Viton® Seals and Elastomers
- One Tool Serviceability, Tool Included with Engine Driven Models (Not with Kits)
- Choice of Briggs & Stratton, Honda Gasoline or Hatz Diesel Engines
- Includes Strainer and Rubber Foot Mounting
- Maximum Temperature 180° F
- Pedestal Versions Available
- Optional High Pressure Hose Kit and Wheel Kit Available
- QSP – Quick Ship Pumps



Manufacturer of AMT & IPT Pumps

400 Spring Street • Royersford, PA 19468 USA

www.amtpump.com • 888-amt-pump (268-7867)

The Gorman-Rupp Company reserves the right to discontinue any model or change specifications at any time without incurring any obligation. ©2012 American Machine and Tool Company. All rights reserved.



0613