



1074 Kenran Industrial Blvd
 Saint Louis, MO 63137
 Phone: (800) 381-9968

HUMCO Lights

C&F 1000W DEC Xenon Searchlight

1000 Watt DEC Xenon Searchlight

80 Million Candlepower with Remote Electric Beam-size

Features



Carlisle & Finch is the standard of the U.S. Navy, U.S. Coast Guard and U.S. Federal Prisons.

- **Beam Intensity:** 80 Million Beam Candlepower illuminates an object/person approximately 9000 meters away on a clear night!
- **Electric Beam-Size Focus:** Beam can be widened and narrowed remote electrically, throughout a continuous spectrum.
- **Beam-size Focus Knob:** External Knob changes beam-size with no tools, and provides back-up should the focus motor fail.
- **Proportional-Speed Joystick:** Speed and Direction are controlled by Joystick... i.e. "Move Joystick to the first position and Beam moves slowly... move the Joystick further and it speeds up!"
- **"Multi-board Safety Back-up"...** electronic power supply design incorporates three boards in parallel, and if one fails, the beam will still operate in back-up mode!
- **Bullet-Resistant Reflector...** Virtually indestructible Nickel Material helps prevent breakage if fixture is hit by bullets or rocks.
- **Anti-icing Heater: (optional):** Thermostatically-controlled heaters are located in the Arm Pivots, Rack and Base.
- **Azimuth Position Indicator (optional):** Position Indicator panel displays where the Beam is aimed in degrees.
- **Thermal Camera (optional):** Optional thermal camera added to searchlight provides additional Night Vision capability.
- **SmartVIEW™ Control (optional):** Micro-processor controls provide intelligent switching throughout a BUS Network, with multiple protocols offered: TCP/IP, RS232, RS422 and RS485.
- **High Powered Strobe (optional):** Powerful nonlethal deterrent disorients intruder and denies night vision.
- **LED Hybrid (optional):** Auxiliary LED Light Modules project a "Wall of Light", 150 Meters Wide and over 230 Meters away, for strategic short range and wide area lighting.

Searchlight Specifications

Electric Beam-Size Focus: 1 to 20° (throughout continuous spectrum)
Temperature Range: -25 °C to +48 °C (approx)
Environmental Protection: IP56
Power Consumption: 115VAC/18 Amps or 230 VAC/9Amps; 50/60HZ
Vertical Span: +35 Deg to -35 Deg (Total 70 Deg approx)
Horizontal Span: Beyond Full Circle (385 Degrees with sliding stop)
Beam Speed: 25° per sec (Horizontal); 14° per sec (Vertical)
Lamp: 1000 Watt, Xenon Short Arc, 6500 °Kelvin
Beam Intensity: 80 Million Candela
Distance Serviced measuring 1 LUX: 8959 Meters on a clear night.
Reflector: Precision Electroformed, Nickel Material, Bullet-Resistant
Materials: Marine Grade Aluminum and Stainless Steel



"Leaders in Searchlight Technology for over 122 years"

Electronic Power Supply

with Multi-Board Safety Back-up Design!

GO GREEN with the C&F 1000 Watt Xenon Power Supply... "Less than 1/3 the weight, Less than 1/3 the size, and 15% more efficient than previous models."

Features

- ⊙ Light Weight
- ⊙ Small Footprint
- ⊙ Improved Efficiency
- ⊙ *Multi-Board Safety Back-up Design
- ⊙ 120 & 230 Volt Models Available
- ⊙ Integrated Hour Meter and Ammeter
- ⊙ Optional Outdoor Models Available
- ⊙ Backward compatible with previous generation power supplies

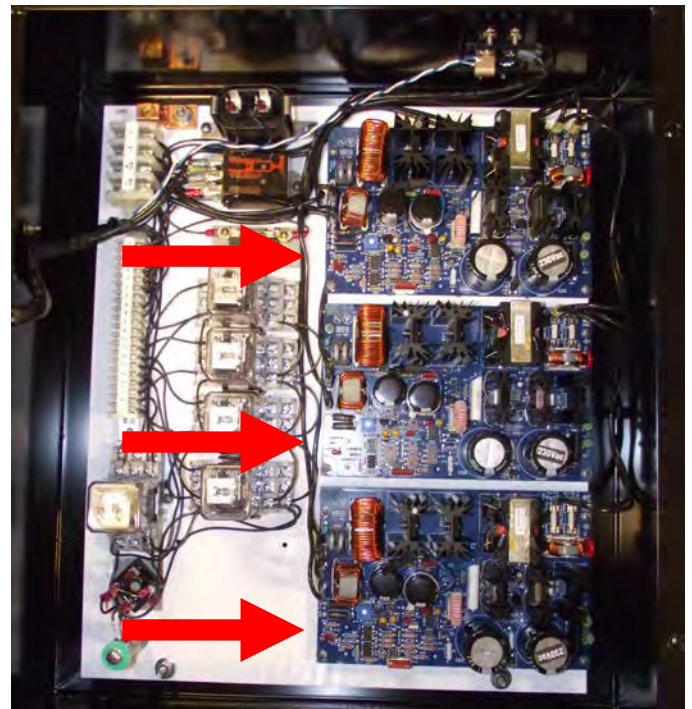

Qty(3) Electronic Boards in parallel provide immediate Safety Back-up!

*Multi-Board Safety Back-up Design: The unique Carlisle & Finch design has multiple electronic boards connected in parallel which provide built-in redundancy. If a board fails, the searchlight will still operate in "back-up" mode. And when there is a board failure, an indicator light on the control panel warns the operator that the light is in "back-up mode", and that the board should be replaced. This feature insures greater searchlight reliability, and is offered by no other searchlight company in the world. Other searchlights, have a complete outage, if an electronic board fails!



"Leaders in Searchlight Technology for over 122 Years"

“Proportional-Speed” Joystick provides Single-Hand operation



The Carlisle & Finch Company offers a “Proportional-Speed Joystick”, which controls the Beam-Speed and Beam-Direction by moving the Joystick with a single hand... i.e. “move the Joystick to the first position, and the Beam moves slowly... move it further and the Beam speeds up!”. Since the need for an additional Speed-Dial or Fast/Slow Switch has now been eliminated (which requires the user to use two hands of operation), the operator can now use his/her free hand to steer the vessel, hold binoculars, or hold a fire arm. Additional Joystick Functions are: Beam-ON, Beam-OFF, Electric Beam-size Focus, Proportional-Speed Joystick (described above), Beam-On Indicator light (offered on Indoor Stations-only), and OverTemp/Hazard Warning Light.



“Leaders in Searchlight Technology for over 122 Years”



1000 Watt Xenon Searchlights Models XE9666-RF and XE9666-HRF Dimensions in Inches (mm)

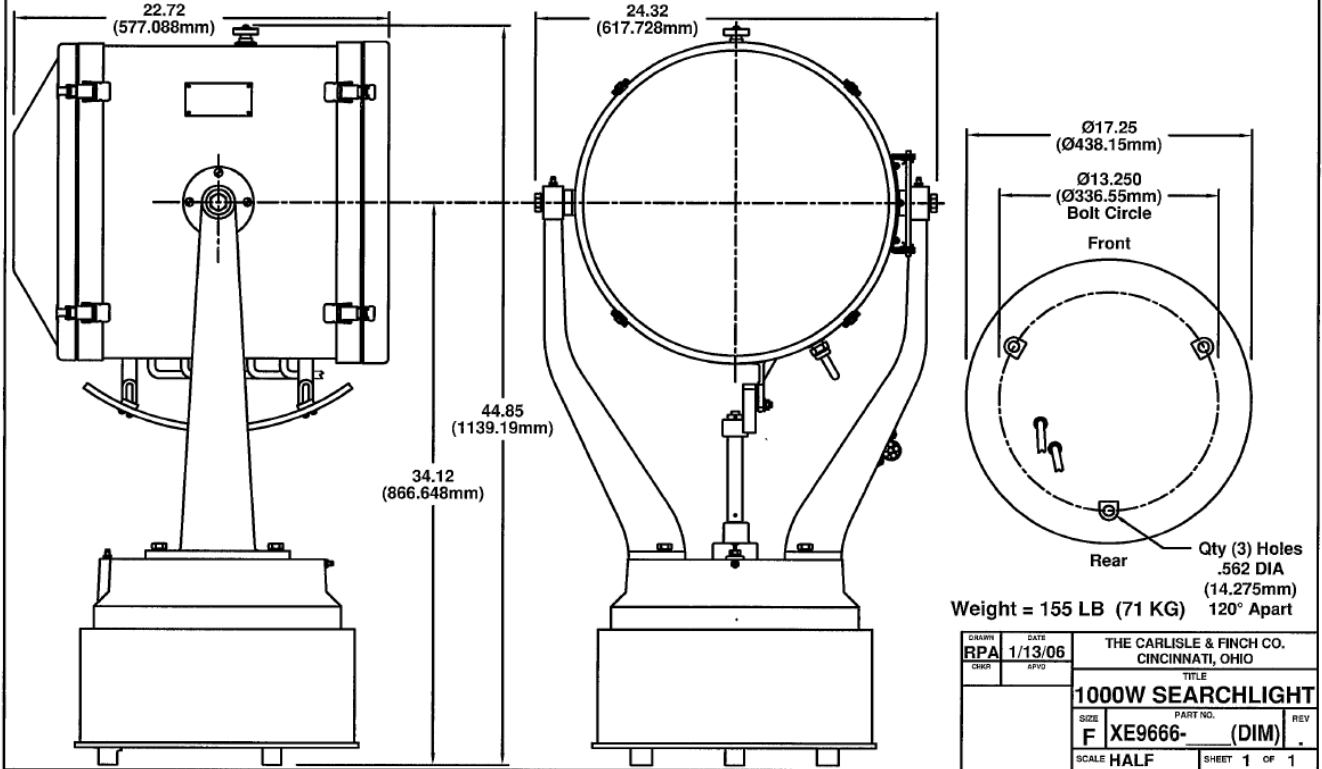

Model 1PS115() & 1PS230() 1000 Watt Xenon Electronic Power Supply Dimensions Inches (mm)

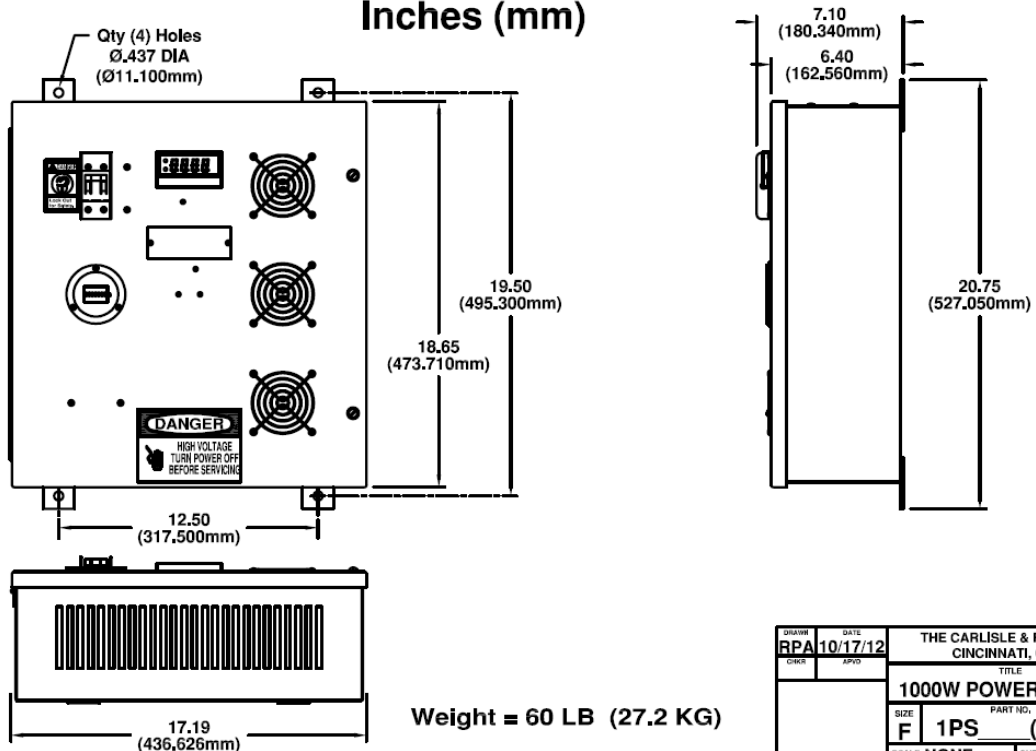

"Leaders in Searchlight Technology for over 122 Years"

Control Station Models C4-1M-2 and C4E1M-2-2 Dimensions in Inches (mm)

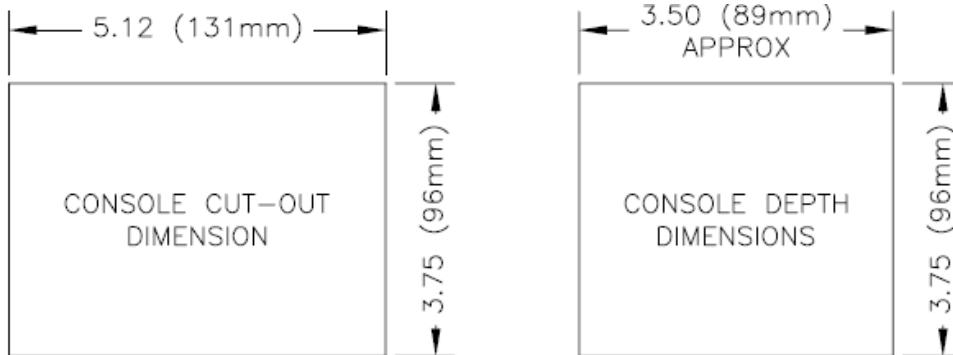
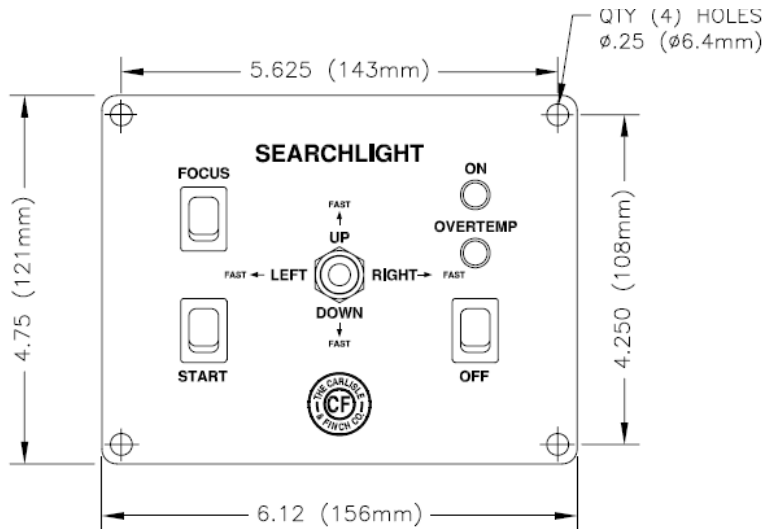

How to Specify a Searchlight System

Searchlight Model	Power Supply Model	Joystick Controller Model
XE9666-RF (Standard) or XE9666-HRF (Includes Anti-icing Heaters)	1PS115DE (115 VAC) or 1PS230DE (230 VAC)	C4-1M-2 (Indoor Station) and/or C4E1M-2-2 (Outdoor Weatherproof Station)

How to Specify a System: Read across the table and select one Searchlight, one Power Supply and one or more Joystick Controllers. For special options listed below, insert the letter into the searchlight model number, to the right of the hyphen, and in alphabetical order.

- To order Anti-icing Heaters add “-H” to the searchlight model number.
- To order Azimuth Position Indicator add “-A” to the searchlight model number.
- To order Full Manual Back add “-M” to the searchlight model number.
- To order a Thermal Camera, LED Hybrid Module, or SmartVIEW™ Controls, consult Factory.

Example Order: Searchlight with Anti-icing Heaters and Azimuth Indicator, 115VAC and (1) indoor and (2) outdoor stations... Qty(1) XE9666-AHRF, Qty(1) 1PS115DE, Qty(1) C4-1M-2 and Qty(2) C4E1M-2-2