



1074 Kenran Industrial Blvd
 Saint Louis, MO 63137
 Phone: (800) 381-9968

HUMCO Lights

C&F 1000W Manual Xenon Searchlight

1000 WATT MANUAL XENON SEARCHLIGHT

80 Million Candlepower with Remote Electric Beam-size

Features

- **Beam Intensity:** 80 Million Beam Candlepower illuminates an object approximately 9000 meters away on a clear night!
- **Electric Beam-Size Focus:** Beam can be widened and narrowed electrically, throughout a continuous spectrum.
- **Beam-size Focus Knob:** External Knob changes beam-size with no tools, and provides back-up should the focus motor fail.
- **Beyond Full Circle of Rotation...** Unique Sliding-Stop Design allows 385 Degrees horizontal motion.
- **“Multi-board Safety Back-up”...** electronic power supply design incorporates three boards in parallel, and if one fails, the beam will still operate in back-up mode!
- **Bullet-Resistant Reflector...** Precision-Optic Reflector with virtually indestructible Nickel Material helps prevent breakage if fixture is impacted by bullets or rocks.
- **Anti-icing Heater: (optional):** Thermostatically-controlled heaters located in the Arm Pivots, Rack and Base.
- **Thermal Camera (optional):** Optional thermal camera added to searchlight provides additional Night Vision capability.
- **High Powered Strobe (optional):** Powerful nonlethal deterrent dis-orients enemy and denies night vision.
- **LED Hybrid (optional):** Auxiliary LED Light Modules project a “Wall of Light”, 150 Meters Wide, and over 230 Meters away, for strategic wide-area, short-range lighting.



Searchlight above shown with the NightFINDER™ Thermal Camera Option!

Searchlight Specifications

Electric Beam-Size Focus: 1 to 20° (throughout continuous spectrum)
Temperature Range: -25 °C to +48 °C (approx)
Environmental Protection: IP56
Power Consumption: 115VAC/18 Amps or 230 VAC/9Amps; 50/60HZ
Vertical Span: +35 Deg to -35 Deg (Total 70 Deg approx)
Horizontal Span: Beyond Full Circle (385 Degrees with sliding stop)
Lamp: 1000 Watt, Xenon Short Arc, 6500 °Kelvin
Beam Intensity: 80 Million Candela
Distance Serviced measuring 1 LUX: 8959 Meters on a clear night
Reflector: Precision Electroformed, Nickel Material, Bullet-Resistant
Materials: Marine Grade Aluminum and Stainless Steel



“Leaders in Searchlight Technology for over 122 years”

Electronic Power Supply

with Multi-Board Safety Back-up Design!

GO GREEN with the C&F 1000 Watt Xenon Power Supply... "Less than 1/3 the weight, Less than 1/3 the size, and 15% more efficient than previous models."

Features

- ⊙ Light Weight
- ⊙ Small Footprint
- ⊙ Improved Efficiency
- ⊙ *Multi-Board Safety Back-up Design
- ⊙ 120 & 230 Volt Models Available
- ⊙ Integrated Hour Meter and Ammeter
- ⊙ Optional Outdoor Models Available
- ⊙ Backward compatible with previous generation power supplies

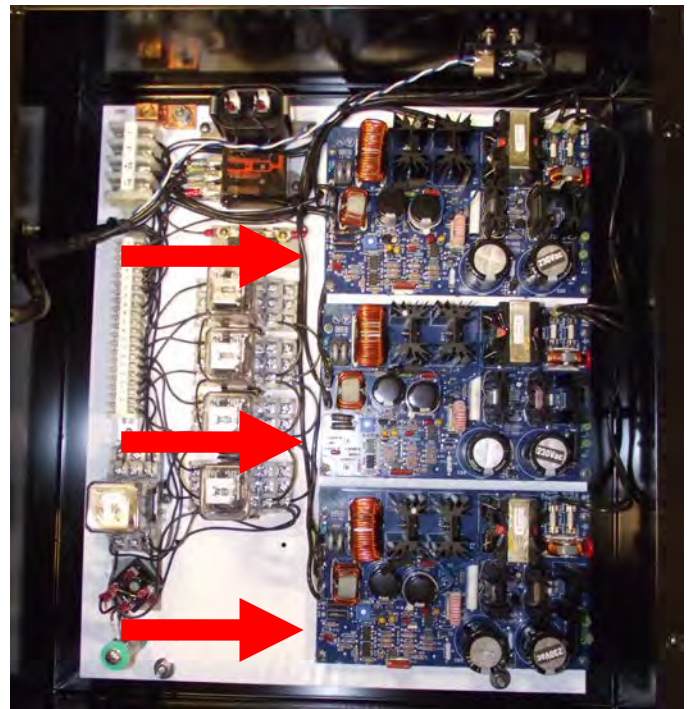

Qty(3) Electronic Boards in parallel provide immediate Safety Back-up!

*Multi-Board Safety Back-up Design: The unique Carlisle & Finch design has multiple electronic boards connected in parallel which provide built-in redundancy. If a board fails, the searchlight will still operate in "back-up" mode. And when there is a board failure, an indicator light on the control panel warns the operator that the light is in "back-up mode", and that the board should be replaced. This feature insures greater searchlight reliability, and is offered by no other searchlight company in the world. Other searchlights, have a complete outage, if an electronic board fails!



"Leaders in Searchlight Technology for over 122 Years"



1000 Watt Xenon Searchlights Models XE9664LG-RF and XE9664LG-HRF Dimensions in Inches (mm)

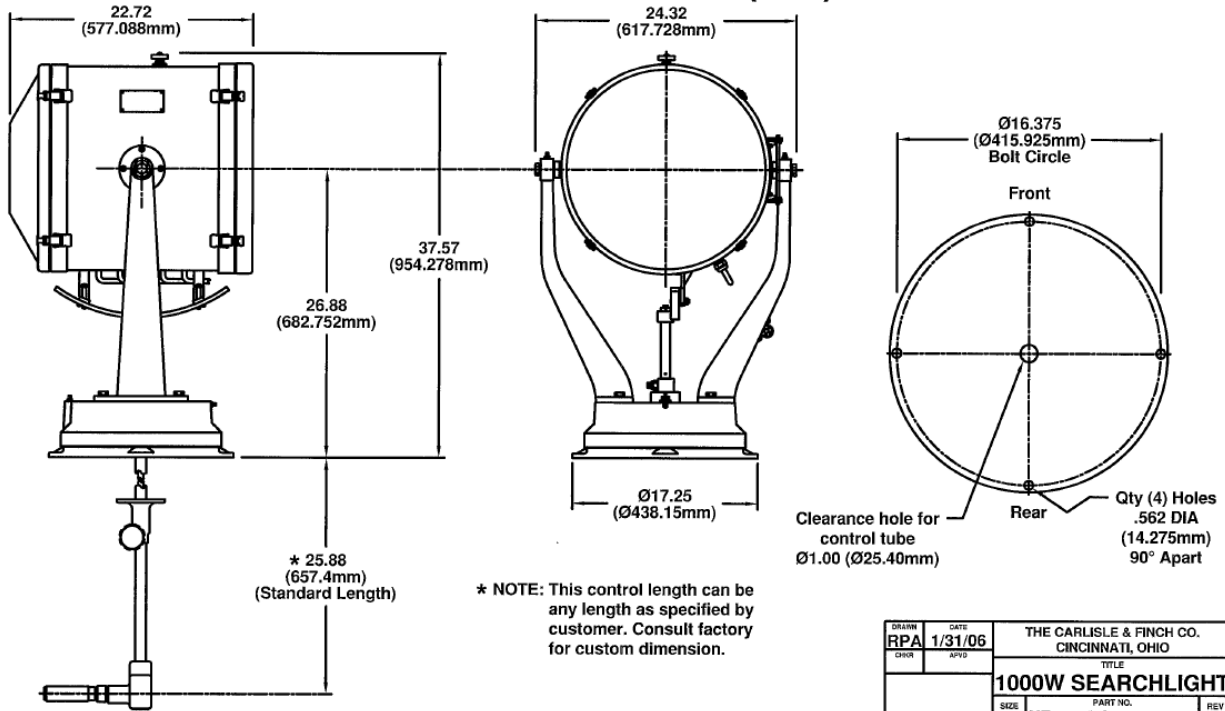

DRAWN	DATE	THE CARLISLE & FINCH CO. CINCINNATI, OHIO	
RPA	1/31/06	TITLE	
CHKD	APVD	1000W SEARCHLIGHT	
		SIZE	PART NO. (DIM) REV
		F	XE9664LG- (DIM) .
		SCALE NONE	SHEET 1 OF 1



Model 1PS115() & 1PS230() 1000 Watt Xenon Electronic Power Supply Dimensions Inches (mm)

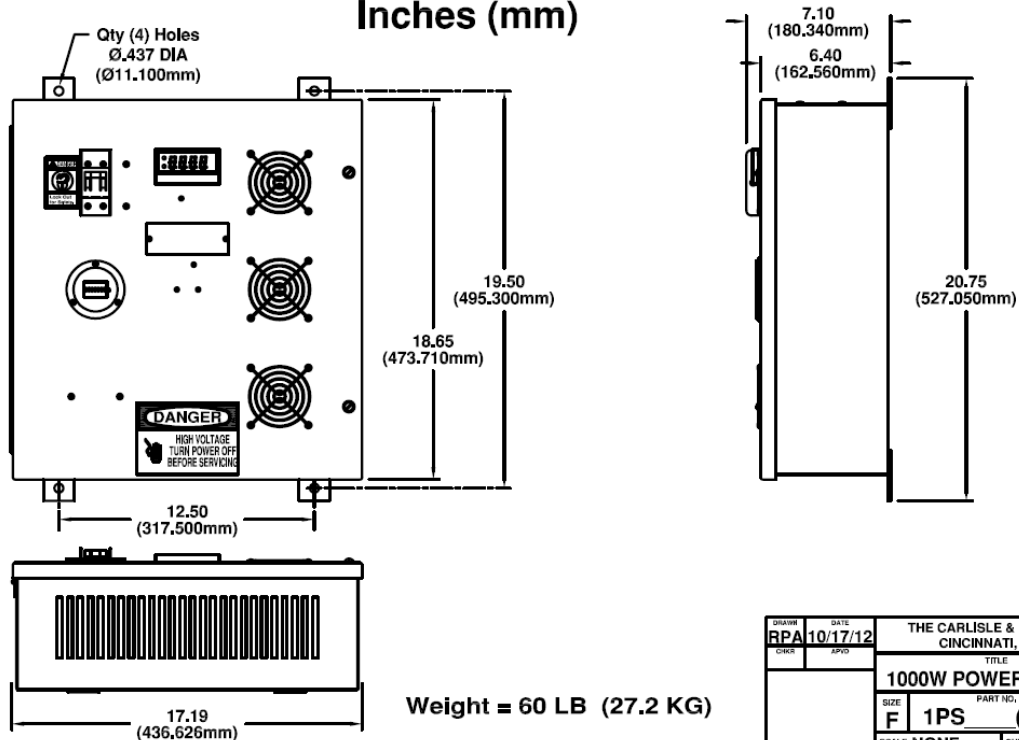

DRAWN	DATE	THE CARLISLE & FINCH CO. CINCINNATI, OHIO	
RPA	10/17/12	TITLE	
CHKD	APVD	1000W POWER SUPPLY	
		SIZE	PART NO. (DIM) REV
		F	1PS (DIM) .
		SCALE NONE	SHEET 1 OF 1



"Leaders in Searchlight Technology for over 122 Years"



1000 Watt Xenon Model 9754X-RF Control Station Dimensions in Inches (mm)

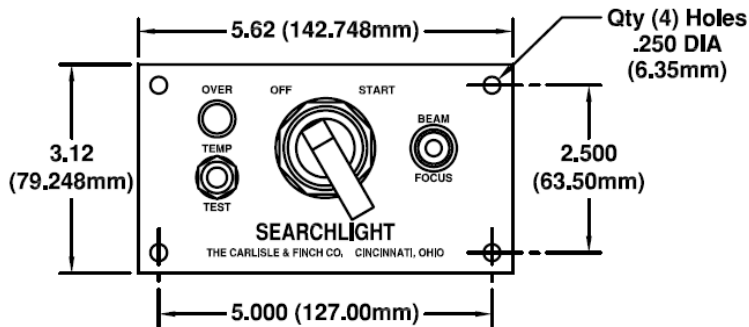
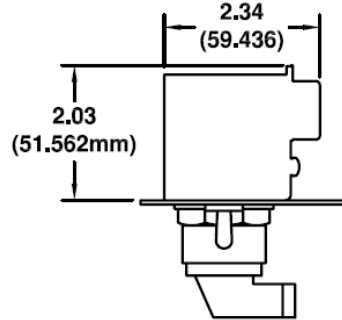
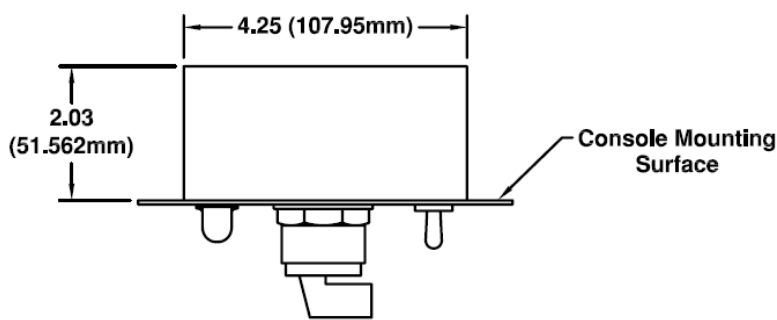

NOTE: Dimensions shown are for Control Panel recessed below console surface. Consult factory for mounting in external enclosure.

Weight = 1 LB (.45 KG)

DATE	1/9/06	THE CARLISLE & FINCH CO. CINCINNATI, OHIO	
BY	RPA	TITLE	
CHKD		CONTROL STATION	
		SIZE	PART NO.
		C	9754X-RF(DIM)
		SCALE	SHEET 1 OF 1

How to Specify a Searchlight System

Searchlight Model	Power Supply Model	Control Station Model
XE9664LG-RF (Standard)	1PS115 (115 VAC)	9754X-RF
or	or	
XE9664LG-HRF (Includes Anti-icing Heaters)	1PS230 (230 VAC)	

How to Specify a System: Read across the table and select one Searchlight, one Power Supply and one 9754X-RF Control Station. NOTE: Then specify Lever Control Length (reference previous page 3, and see the dimension *25.88 inches marked by the asterisk. This is the standard length, but this dimension can be specified to the customer's exact requirement. Please consult Factory for any custom control length you desire.

Example Order: Searchlight with Anti-icing Heaters and 115VAC Input... Qty(1) XE9664LG-HRF, Qty(1) 1PS115, and Qty(1) 9754X-RF.